

**OREGON OCCUPATIONAL SAFETY AND HEALTH DIVISION  
DEPARTMENT OF CONSUMER AND BUSINESS SERVICES**

---

**PROGRAM DIRECTIVE**

Program Directive: PD-268  
Issued: July 16, 2008  
Revised: May 24, 2010

**SUBJECT:** National Emphasis Program (NEP): Combustible Dust

**AFFECTED STANDARDS/DIRECTIVES:** General Industry and Agriculture

**PURPOSE:** This instruction contains policies and procedures for inspecting workplaces that have combustible dusts that are likely to cause dust deflagrations, other fires, or explosions. These dusts include, but are not limited to:

- Metal dust such as aluminum and magnesium
- Wood dust
- Coal and other carbon dusts
- Plastic dust and additives
- Biosolids
- Other organic dust such as sugar, flour, paper, soap, and dried blood
- Certain textile materials.

Industries that handle combustible dusts include, but are not limited to:

- |                                                         |                        |
|---------------------------------------------------------|------------------------|
| • Agriculture                                           | • Food products        |
| • Chemicals                                             | • Textiles             |
| • Forest and furniture products                         | • Metal processing     |
| • Tire and rubber manufacturing plants                  | • Paper products       |
| • Pharmaceuticals                                       | • Wastewater treatment |
| • Recycling operations (metal, paper, and plastic)      |                        |
| • Coal dust in coal handling and processing facilities. |                        |

**(Note:** OSHA Standard 1910.269(v)(11)(xii) addresses control of ignition sources at coal handling operations in electric power plants. 1910.272 addresses grain handling facilities. See Oregon OSHA Program Directive A-189 for additional guidance. The Mine Safety and Health Administration (MSHA) has authority in some areas involving coal crushing and conveying. See Oregon OSHA Program Directive A-114 (Jurisdiction: MSHA), for additional guidance on authority.)

**SCOPE:** This instruction applies to all of Oregon OSHA.

**REFERENCES: See - Appendix G**

**BACKGROUND:** Dust deflagration, other fire, and explosion hazards in the industries noted in the purpose of this directive are covered by several Oregon OSHA standards and the Oregon Safe Employment Act. A dust deflagration occurs when the right concentration of finely divided dust particles are suspended in air and then exposed to a sufficient source of ignition to cause ignition (combustion) of the dust. If the deflagration is in a confined area, an explosion potential exists. These materials can also cause other fires. Combustible dust is often either organic or metal dust that is finely ground into very small particles. The actual quantity of dust that may accumulate in an affected area may vary depending upon air movement, particle size, or any number of other factors.

Oregon OSHA is initiating this NEP to address the deflagration, other fire, and explosion hazards associated with most combustible dusts. It is issued in response to a number of combustible dust accidents which have resulted in deaths and serious injuries.

In Oregon, these dust-related incidents were identified:

Commercial Furniture, Roseburg, May 16, 2006: An employee suffered second- and third-degree burns on his hands and arms from a dust fire after two workers changed a bag filter on a powder coating line for office furniture.

Ace International, Albany, August 11, 2003: A worker died after suffering burns and inhaling toxic, superheated air. A defective piece of electrical equipment created a spark that ignited wood flour and dust.

Mill Rite Farms, Albany, August 8, 2002: Workers were processing feed pellets when the system failed. An employee went upstairs to investigate and was killed when dust in the air exploded and set off a fire. Two other employees suffered serious burns and smoke inhalation.

Willamette Industries, Albany, October 25, 2000: An employee died from burns from a combustible dust fire. The employee had changed a light bulb that was covered with wood dust. Investigators found large amounts of wood flour and dust on equipment and lighting fixtures.

In other parts of the country these incidents were identified:

In 1999, a primary explosion of natural gas in an idle power boiler followed by a secondary explosion of disturbed coal dust in the facility caused six fatalities and fourteen serious injuries in a Michigan electrical power generation facility. (See Safety and Health Information Bulletin: Potential for Natural Gas and Coal Dust Explosions in Electrical Power Generating Facilities.)

In May 2002, an explosion occurred at Rouse Polymerics International, Inc., a rubber fabricating plant, in Vicksburg, Mississippi, which injured eleven employees, five of whom later died of severe burns. The explosion occurred when highly combustible rubber dust that had been allowed to accumulate ignited.

On January 29, 2003, an explosion and fire destroyed the West Pharmaceutical Services plant in Kinston, North Carolina, causing six deaths, dozens of injuries, and hundreds of job losses. The facility produced rubber stoppers and other products for medical use. The fuel for the explosion was a fine plastic powder, which accumulated above a suspended ceiling over a manufacturing area at the plant and ignited.

On February 20, 2003, an explosion and fire damaged the CTA Acoustics manufacturing plant in Corbin, Kentucky, fatally injuring seven employees. The facility produced fiberglass insulation for the automotive industry. The resin involved was a phenolic binder used in producing fiberglass mats.

On the evening of October 29, 2003, a series of explosions severely burned three employees, one fatally, and caused property damage to the Hayes Lemmerz manufacturing plant in Huntington, Indiana. One of the severely burned men subsequently died. The Hayes Lemmerz plant manufactures cast aluminum automotive wheels, and the explosions were fueled by accumulated aluminum dust, a combustible by-product of the wheel production process.

These explosions in Michigan, Mississippi, North Carolina, Kentucky, and Indiana resulted in the loss of 25 lives and caused numerous injuries and substantial property losses.

**DEFINITIONS:** The following is a **partial listing** of definitions based on NFPA standards and 1910.399, the definitions provision of Subpart S—Electrical, that relate to combustible dust.

**A. Class II locations.** Class II locations are those that are hazardous because of the presence of combustible dust. The following are Class II locations where combustible dust atmospheres are present:

**Group E.** Atmospheres containing combustible metal dusts, including aluminum, magnesium, and their commercial alloys, and other combustible dusts whose particle size, abrasiveness, and conductivity present similar hazards in the use of electrical equipment.

**Group F.** Atmospheres containing combustible carbonaceous dusts that have more than 8 percent total entrapped volatiles (see ASTM D 3175, Standard Test Method for Volatile Matter in the Analysis Sample of Coal and Coke, for coal and coke dusts) or that have been sensitized by other materials so that they present an explosion hazard. Coal, carbon black, charcoal, and coke dusts are examples of carbonaceous dusts.

**Group G.** Atmospheres containing other combustible dusts, including flour, grain, wood flour, plastic and chemicals.

**B. Combustible dust.** A combustible particulate solid that presents a fire or deflagration hazard when suspended in air or some other oxidizing medium over a range of concentrations, regardless of particle size or shape.

**C. Combustible Particulate Solid.** Any combustible solid material composed of distinct particles or pieces, regardless of size, shape, or chemical composition.

**D. Hybrid Mixture.** A mixture of a flammable gas with either a combustible dust or a combustible mist.

**E. Deflagration.** Propagation of a combustion zone at a speed that is less than the speed of sound in the unreacted medium.

**F. Deflagration Isolation.** A method employing equipment and procedures that interrupts the propagation of a deflagration of a flame front, past a predetermined point.

**G. Deflagration Suppression.** The technique of detecting and arresting combustion in a confined space while the combustion is still in its incipient stage, thus preventing the development of pressures that could result in an explosion.

**H. Detonation.** Propagation of a combustion zone at a velocity that is greater than the speed of sound in the unreacted medium.

**I. Dust-ignition proof.** Equipment enclosed in a manner that excludes dusts and does not permit arcs, sparks, or heat otherwise generated or liberated inside of the enclosure to cause ignition of exterior accumulations or atmospheric suspensions of a specified dust on or in the vicinity of the enclosure.

**J. Dust tight.** Enclosures constructed so that dust will not enter under specified test conditions.

**K. Explosion.** The bursting or rupture of an enclosure or a container due to internal pressure from deflagration.

**L. Minimum Explosible Concentration (MEC).** The minimum concentration of combustible dust suspended in air, measured in mass per unit volume that will support a deflagration.

## PROGRAM PROCEDURES:

- A. Inspection Scheduling.** Inspections conducted under this NEP will focus on general industry facilities and agriculture activities where employees may be exposed to potential combustible dust hazards.

Safety Inspection Scheduling: The hazards associated with combustible dusts will be addressed within the existing inspection scheduling systems.

### Health Inspection Scheduling:

1. For Appendices D-1 and D-2, two statewide master lists of employers with active workers compensation coverage within these NAICS will be generated.
2. From the D-1 list, the two NAICS with the most employers will be selected initially for inspection. From the D-2 list, the NAICS with the most employers will be selected initially for inspection.
3. These two lists will be sorted by field office and then alphabetically. If they are an active employer, each establishment will be given a sequential number, then a random number. The random number will then be put in sequential order.
4. Each field office list for D-1 and D-2 are randomized and given to each health enforcement manager. Health enforcement managers are responsible for the administration of the regional lists under their jurisdiction.
5. Each field office will start with the number one and go down the list. The first 10 may be scheduled and inspected in any order that makes efficient use of resources. All 10 must have inspections initiated before going on to the next 10.
6. Additions or deletions to the field office lists may be made based on familiarity with these local industries. Previous health and safety inspection history will be considered when evaluating combustible dust hazards within the selected NAICS.
7. 75% of the health inspections will be done from the D-1 list; 25% from the D-2 list.
8. Inspection lists for other NAICS may be developed independently from the master list by each field office as resources allow.

Safety and Health Enforcement Managers: will coordinate inspection activities covered by the NEP to assure timely and effective use of resources. A determination should be made as to whether combustible dust has been addressed on recent inspections and whether conditions exist that would call for a repeat inspection related to combustible dust.

### **B. Scheduling and Resource Allocation.**

1. When hazards related to combustible dust are encountered during any scheduled inspection, the CSHO will determine, with their health or safety enforcement manager, the best way to address the hazard.
2. If a complaint or referral is received related to combustible dust, the complaint or referral items must be investigated or inspected according to Program Directive A-219, Inspection Criteria: Complaint Policies and Procedures. Inspection procedures in this directive will be followed.

3. Responses to accidents and catastrophes at facilities handling combustible dust must follow the guidelines contained in Program Directive A-165, Inspection Criteria: Oregon OSHA Response to Significant Events of Potentially Catastrophic Consequence, in addition to the guidelines contained in this instruction. If a fatality or catastrophe investigation arises at a facility due to a combustible dust deflagration or explosion, the accident must be investigated and an inspection as required under this NEP must be conducted.

**C. Opening Conference.**

1. During the opening conference and after a preliminary walk-around of the facility, if the CSHO determines that the employer's operation does not have combustible dust explosion, deflagration, or other fire hazards, then the compliance officer may terminate the inspection.
2. During the opening conference, if the CSHO determines that the facility being inspected is covered under the grain handling standard (1910.272), then the CSHO must not use the guidance provided in this instruction, but instead, must use the guidance provided in Program Directive A-189, Grain Handling Facilities.

**D. Resources.**

1. When possible, only CSHOs trained in recognizing the hazards associated with combustible dust will be assigned to conduct inspections under this NEP. When a CSHO determines that combustible dust hazards exist within a workplace, the CSHO should discuss with their respective manager whether a referral should be made or other expertise is needed to address these hazards.
2. Oregon OSHA's Resource Library has industry reference documents available to use as a resource to support research and enforcement activities during the inspection. See appendix A for a list of NFPA documents. (Remember to refer to the specific NFPA for the dust hazard you may encounter, for example for wood dust refer to NFPA 664)
3. Oregon OSHA safety and health staff must take appropriate precautionary measures for the particular hazards presented in facilities with combustible dust hazards.
  - a. Personal protective equipment (PPE): In addition to the normally required personal protective equipment, staff will wear non-spark producing clothing such as natural fiber (e.g., cotton). Flame-resistant clothing will be provided as appropriate.
  - b. Equipment: Use cameras and video cameras appropriate (for example, intrinsically safe) for the work environment. However, if such cameras are not available, then staff must take photographs or videos (using a telephoto feature) from locations within the plant that are not hazardous (classified) locations. Additionally, CSHOs must take written statements from employees, and if possible from employers, regarding the hazardous conditions, including the alleged violative conditions (such as dust accumulations over 1/32-inch,

explosion vents not directed to safe locations away from the employees working in the area, etc.).

- c. Use safe practices when collecting samples, such as not generating a dust cloud while collecting a sample and using the right tools in collecting the samples. Additionally, if a means of safe access is not available, sample(s) should not be collected.
- d. Equipment for collecting dust samples may include the following:
  - Natural bristle hand brushes for collecting settled dust.
  - Non-sparking, conductive dust pans (aluminum), for collecting settled dust.
  - Non-spark producing sample container.
  - Non-spark producing funnel for filling sample containers.
  - Non-spark producing scoops for removing dust from cyclone containers or other ventilation equipment.
- e. Care must be taken to ensure integrity of the sample.

## **E. Inspection and Citation Procedures.**

1. The following criteria must be met before a deflagration can occur:
  - a. The dust has to be combustible.
  - b. The dust has to be dispersed in air or another oxidant, and the concentration of this dispersed dust is at or above the minimum explosible concentration (MEC).
  - c. There is an ignition source, such as an electrostatic discharge, spark, glowing ember, hot surface, friction heat, or a flame that can ignite the dispersed combustible mixture that is at or above the MEC.
2. The following criteria must be met before an explosion can occur:
  - a. The above criteria for deflagration must be present.
  - b. The combustible mixture is dispersed within a confined enclosure, and the confined enclosure does not contain sufficient deflagration venting capacity to safely release the pressures such as a vessel, storage bin, ductwork, room or building. It must be noted that a small deflagration can disturb and suspend the combustible dust, which could then serve as the fuel for a secondary and often more damaging deflagration or explosion.
3. The following conditions may indicate that a potential dust deflagration, other fire, or explosion hazard exists:

- a. **Plant history of fires:** The plant has a history of fires involving combustible dusts.
- b. **Material safety data sheets (MSDS):** The MSDS may indicate that a particular dust is combustible and can cause explosions, deflagrations, or other fires. However, do not use MSDSs as a sole source of information because this information is often excluded from MSDSs.
- c. **Dust accumulations:** Referring to NFPA 654, Annex D, there contains guidance on dust layer characterization and precautions. It indicates that immediate cleaning is warranted whenever a dust layer of 1/32-inch thickness accumulates over a surface area of at least 5% of the floor area of the facility or any given room. The 5% factor should not be used if the floor area exceeds 20,000 ft<sup>2</sup>, in which case a 1,000 ft<sup>2</sup> layer of dust is the upper limit. Accumulations on overhead beams, joists, ducts, the tops of equipment, and other surfaces should be included when determining the dust coverage area. Even vertical surfaces should be included if the dust is adhering to them. Rough calculations show that the available surface area of bar joists is approximately 5% of the floor area and the equivalent surface area for steel beams can be as high as 10%. The material in Annex D is an idealized approach based on certain assumptions, including uniformity of the dust layer covering the surfaces, a bulk density of 75 lb/ ft<sup>3</sup>, a dust concentration of 0.35 oz/ ft<sup>3</sup>, and a dust cloud height of 10 ft. Additionally, FM Data Sheet 7-76 contains a formula to determine the dust thickness that may create an explosion hazard in a room, when some of these variables differ.
- d. CSHOs should observe areas of the plant for accumulations of hazardous levels of dust (for example, greater than 1/32 of an inch, which is approximately equal to the thickness of a typical paper clip). Likely areas of dust accumulations within a plant are:
  - structural members
  - conduit and pipe racks
  - cable trays
  - floors
  - above ceiling
  - on and around equipment (leaks around dust collectors and ductwork)
- e. Dust samples must be collected safely. Staff should only access upper levels of a facility when it can be done safely. Locations to collect separate samples:
  - “High spaces” such as roof beams, open web beams, tops of pipes and ductwork, and other horizontal surfaces located as high in the overhead as possible.
  - Equipment and floors where dust has accumulated.
  - The interior (i.e., bins and/or bags) of a dust collector.
  - Within ductwork.

Note: These are the preferred locations; however, if a safe access is not available, samples should not be collected.

4. **Laboratory tests.** The following are a series of tests which may be performed to determine the explosibility and combustibility parameters of the dust samples submitted. Samples submitted to Oregon OSHA's Lab need to have the field office manager's approval to be sent to OSHA's Salt Lake Technical Center (SLTC). **Consultation samples will not be submitted to SLTC.** Details on these tests are found in appendix E.

OSHA's SLTC performs the following tests: CHSO's need to be clear on what test they request to be done.

- Percent through 40 mesh
- Percent moisture content
- *Percent combustible material (used only for grain handling facilities)*
- *Percent combustible dust (used only for grain handling facilities)*
- Metal dusts will include resistivity
- Minimum explosive concentration (MEC)
- Minimum ignition energy (MIE)
- Class II test
- Sample weight
- Maximum normalized rate of pressure rise (dP/dt) – Kst Test
- Minimum ignition temperature

5. **Sampling & analytical methods.**

- Air sampling is not necessary.
- At a minimum, the Oregon OSHA Laboratory needs one bulk sample in a 1-liter plastic bottle. These bottles may be obtained from the Oregon OSHA Laboratory. Obtain samples from several locations so that the amount can be collected in a 1-liter plastic bottle. The lab will be responsible for submitting samples to STLC.
- Affix an official sample identification seal on the container. To seal the bottle correctly, apply one end of the seal to the center of the lid. Then run the seal to the edge of the lid and as far down the side of the bottle as it will reach.
- Preferably, sample materials should not be collected in plastic bags because they cannot be sealed tightly enough to prevent sample leakage or moisture loss. Also, these bags have a bellows effect which can make the dust airborne when handling the samples.
- CSHOs should take precautions not to contaminate the sample material. Some contaminants in a sample may result in the tests' underreporting the explosiveness of the dust handled at the facility.
- Document the description of the operation on the OSHA 91(S) as follows:

- When requesting analyses for fire or explosion hazards that may result from housekeeping or Division 1 violations, write “Kst.”
- When requesting analyses for Class II hazardous locations, write “Potential Class II Dust.” This test must be done to support a citation for Class II hazardous (classified) locations, 1910.307. Note: This test only applies to electrical ignition sources in Class II locations.
- Because of the resource intensive nature of the tests, samples submitted by the Oregon OSHA Lab to SLTC requires the field office manager’s agreement for all combustibility and explosibility testing.

**6. Lab results.**

SLTC Lab results may contain some of the results listed below, but not all, depending on particular tests that are performed:

- |                            |                               |            |
|----------------------------|-------------------------------|------------|
| • Mesh size                | • Moisture content            | • Class II |
| • Percent combustible dust | • Sample weight               |            |
| • Explosion severity       | • Kst value                   |            |
| • MEC                      | • Resistivity for metal dusts |            |

**7. Dust collectors, ductwork, and other containers.** Staff should also pay attention to the dust collectors and ductwork, as well as other containers, because they maintain a cloud of finely divided particles suspended in air. Staff should determine whether the plant has a sound ignition control program that prevents introduction of ignition sources (including sparks from electrostatic discharge, open flames, or other similar sources) into them. Additionally, housekeeping problems may be exacerbated by the inefficient operation of dust collectors. As noted in NFPA 654, Annex D.2, dust collectors generally operate most effectively between limited pressure drops of between 3 inches to 5 inches of water. If the employer does not have a hot work permit system that addresses hot work on and around collection points and ductwork or in areas where hazardous levels of dust accumulations may occur, the CSHO should recommend that such a system be immediately implemented. In Division 1 cases, a hot work permit system may be noted as a feasible abatement method. For chemicals covered by 1910.119 (PSM), the standard requires a hot work permit system. See 1910.119(k).

**8. Efforts the employer has made to abate the combustible dust hazard.**

This information will be helpful in determining some violations, as well as the employer’s good faith effort. Look at dust collectors, ductwork, associated equipment, and containers, like mixers or storage bins. The following information may be gathered during the course of the inspection:

**NOTE:** Because of its spark-producing potential, no equipment, including cameras with electronic flashes or electrical equipment will be used in hazardous (classified) locations of the facilities, unless the equipment is intrinsically safe, approved, or safe, as defined in 1910.307(b), for use in these types of areas.

- Explosion prevention and mitigation controls such as the isolation or segregation of dust-generating processes, building damage-limiting construction, explosion venting for dust processing areas; process equipment relief (see NFPA 68), and process isolation and explosion suppression (see NFPA 69).
- The dimensions of the room as well as the areas of the dust accumulations of greater than 1/32-inch depth.
- The design information on the dust collection systems, along with model numbers and serial numbers (located on the side of the equipment along with the manufacturer and phone numbers).
- Size (volume) of dust collectors Note: Dust collectors are referred to as “air-material separators” in NFPA 654.
- Warning signs or alerts on the equipment referencing combustible dust.
- Sources of ignition in the area, such as welding, fork truck traffic, etc.
- Information on whether the electrical equipment in the area is designed for use in a hazardous (classified) location. Note: Do not open electrical boxes or disconnect electrical cords. Opening them could cause an electrical arc, especially in an area with metal dust.
- Information on past fires or explosions at the facility.
- Information on enclosurless dust collectors (EDC) used by the employer. EDC’s are a type of dust collector that may be used for **wood** dust. Indoor use of EDC’s are allowed under very specific conditions (meeting **all** of the following) found in 2007 edition of NFPA 664 8.2.2.5.1.4(7). A specific definition is also in this NFPA 664 3.3.9.2. Further conditions with regard to EDC’s include:
  - Flexible hoses used to convey air constructed of metal or other conductive materials must be grounded.
  - When a dust collection system is used, the guard and hood must be constructed of material per 8.2.2.3 and there must be a provision in all operations for the removal of refuse when refuse is too heavy, bulky or otherwise unsuitable to be handled by the dust collection systems.

**9. Citations. If a violation is discovered, cite the vertical standard that addresses the combustible dust hazard.**

- a. **Grain handling standard violations.** For violations at grain handling facilities (e.g., flour mills), issue citations under 1910.272. (See PD A-189, Grain Handling Facilities, 1910.272.) **NOTE:** 1910.272(j)(2) applies only to grain elevators, bucket conveyors, and legs of elevators – not to processing or mill operations. Other areas of the processing or mill operations fall under 1910.22, Housekeeping.

- b. **Ventilation standard violations.** If the facility's operations are covered by 1910.94, Ventilation, then use that standard for any violations. Paragraph (a) of the standard covers abrasive blasting; paragraph (b), grinding, polishing, and buffing operations.
- c. **Housekeeping violations.** If the facility inspected under this NEP is not a grain handling facility (see exception above), and the surface dust accumulations (i.e., dust accumulations outside the dust collection system or other containers, such as mixers) can create an explosion, deflagration or other fire hazard, then cite 1910.22, Housekeeping. The standard provides, in pertinent part, "(a) Housekeeping. (1) All places of employment, passageways ... and service rooms must be kept clean... (2) The floor of every workroom must be maintained in a clean...condition." Courts of appeals and the Occupational Safety and Health Review Commission have held that 1910.22 applies to the hazard of combustible dust. *Con Agra, Inc. v. OSHRC*, 672 F.2d 699 (8th Cir. 1982); *Bunge Corp. v. Secretary of Labor*, 638 F.2d 831 (5th Cir. 1981); *Farmers Cooperative Grain and Supply Company*, 10 BNA OSHC 2086 (No. 79-1177, 1982).
- Issue citations for violations of 1910.22(a)(1) when the levels of dust accumulations exist in places of employment (except floors of workrooms and storage areas), passageways, and service rooms in such depths that they can present explosion, deflagration or other fire hazards.
  - Issue citations for 1910.22(a)(2) when the levels of dust accumulations exist on the floors of workrooms in such depths that they can present explosion, deflagration, or other fire hazards.

Small amounts of dust accumulations in isolated spots of the floor or other areas would not normally be classified as a violation of the housekeeping requirement under this NEP. In order to substantiate housekeeping violations, CSHOs must take representative measurements. Thickness measurements must be made at several locations within the sampling area. For a large area, a paint brush and dustpan can be used. For a small area, a high-volume pump pulling through a filtered cassette may be used to collect the sample. As a part of determining whether the housekeeping violation is serious, CSHOs should determine whether the dust is combustible or can cause deflagration by submitting the sample to the Occupational Health Lab and obtaining its analysis. In addition, CSHOs should also document the heat and ignition sources.

In coal-handling operations located in electric power generation, transmission, and distribution facilities, 1910.22 must not be cited for coal dust accumulations. Instead, cite 1910.269(v)(11)(xii).

**NOTE:** This NEP should not be construed to interfere with the application of 1910.22 or other housekeeping standards to the uncleanliness of workplaces, unrelated to the combustible dust hazard.

- d. **Housekeeping violations in storage areas.** Cite 1910.176(c) for housekeeping violations in storage areas. The standard provides, in pertinent part, “(c) Housekeeping. Storage areas shall be kept free from accumulation of materials that constitute hazards from ...fire, explosion...” Use the same criteria as dust hazard under 1910.22(a) to determine 1910.176(c) violations. Document whether a reasonable person would recognize a combustible dust hazard under the circumstances. NFPA standards may be relied upon in this regard. See, NFPA 654 (2006), Standard for the Prevention of Fire and Dust Explosions from the Manufacturing, Processing, and Handling of Combustible Particulate Solids. CSHOs must also document feasible abatement methods. See, NFPA 654.
- e. **Division 1, OAR 437-001-0760, Rules for all Workplaces, violations.** A citation under 437-001-0760(1)(b)(C) may be issued for deflagration, explosion, or other fire hazards that may be caused by combustible dust within a dust collection system or other containers, such as mixers.

The following are some conditions for which this rule may be used:

- Problems related to dust collectors, such as dust collection equipment located inside the building, although there are some exceptions, and dust collectors returning air back inside the building.
- Ductwork-related problems, e.g., the ductwork not being grounded and ductwork not constructed of metal.
- Improperly designed deflagration venting (venting to areas where employees are likely to be exposed to explosion/ deflagration hazards).
- Processing and material handling equipment not protected by deflagration suppression systems, such as mixers, blenders, pulverizers, mills, dryers, ovens, filters, dust collectors, pneumatic conveyors, and screw conveyors.
- Equipment connected by pipes and ducts not protected by deflagration isolation systems, such as flame arresters, flame front diverters, spark detection, spark extinguishing equipment, and rotary valves.

If these situations are encountered, refer to the appropriate standards:

- When inspecting bakery equipment in a bakery covered under 1910.263, Division 1 citations will not be issued for fire and explosion hazards in connection with sugar and spice pulverizers, covered under 1910.263(k)(2).
- Explosion hazards from blower collection and exhaust systems in sawmill operations are covered under 1910.265(c)(20)(i).

OAR 437-001-0760(1)(b)(C) may also be used if SLTC finds Kst values of the submitted dust sample are greater than zero, and for other fire hazards if SLTC determines that the dust is combustible. (See appendix E for more details on combustible dust tests, including the Kst test and its associated values relative to degree of explosion.)

These resources are useful in establishing industry knowledge of combustible dust hazards:

- The NFPA standards, which represent the opinions of experts familiar with combustible dust hazards, are useful in providing evidence of industry recognition of the hazard. (See NFPA 654 (2006), Standard for the Prevention of Fire and Dust Explosions from the Manufacturing, Processing, and Handling of Combustible Particulate Solids.) (See *Kelly Springfield Tire Co., Inc. v. Donovan*, 729 F.2d 317 (5th Cir. 1984) – recognition of combustible dust hazard based on testimony of expert employed by dust collection equipment manufacturer.)
- CSHOs must look at the employer’s safety manuals or other instructions to determine whether there is employer recognition of the combustible dust hazard. Heat and ignition sources should also be documented. If such articles or employer documents are unavailable, CSHOs may rely upon the NFPA standards for evidence of recognition of the hazard.

The procedures outlined in the Oregon OSHA FIRM will be followed when ORS 654.010 General Duty citations are issued. The essence of a general duty citation is the hazard. A separate general duty citation will not be issued for a failure to use a particular abatement method. For evidence of feasible means of abatement, CSHOs should consult relevant NFPA standards. If all the elements of a general duty violation cannot be documented for the hazards noted during an inspection, then a hazard alert letter will be issued to the employer for such hazards. The Department of Justice must be consulted prior to issuing any general duty citations. The health field operations manager must approve general duty citations prior to issuance.

- f. **Housekeeping violations at coal-handling operations covered under 1910.269.** If violations of 1910.269(v)(11)(xii) (sources of ignition not eliminated or controlled where coal-handling operations may produce a combustible atmosphere from fuel sources) are identified during an inspection of a coal-fired power plant, that provision must be cited, not 1910.22 or Division 1.
- g. **Personal protective equipment (PPE) violations.** Citations under 1910.132(a), which is the general requirement to provide and assure the use of protective equipment, including protective clothing, may be issued if an employee exposure to potential burn injuries can be documented. For example, if employees are not wearing protective clothing, such as flame-resistant clothing in areas of the plant (e.g., bagging areas) where employees may be exposed to potential combustible dust flash fire hazards, then citations under 1910.132(a) may be issued. Another example where citations under 1910.132(a) may be issued is in a situation where employees, not

wearing flame-resistant clothing and cleaning out a piece of equipment containing combustible dust, may be exposed to a flash fire propagated through the cleanout door. A citation may be issued whether or not an accident precipitated the inspection.

Document whether a reasonable person familiar with the circumstances would recognize hazards from combustible dust. NFPA standards may be used for this documentation. Also document whether there are feasible types of personal protective equipment to deal with these hazards. It has been recognized as industry practice to require flame-resistant clothing when employees may be exposed to flash fire hazards. NFPA 2113, *Standard on Selection, Care, Use and Maintenance of Flame-Resistant Garments for Protection of Industrial Personnel Against Flash Fire* is a national consensus standard which applies to chemical, refining, and terminal facilities with flash fire hazards. Among other provisions, NFPA 2113 has requirements for when flame-resistant clothing must be used by industrial personnel exposed to flash fire hazards. See chapter 4 of NFPA 2113 for a discussion on selection of flame-resistant clothing.

- h. **Process safety management.** If the dust in question appears on the list of highly hazardous chemicals (Appendix A to 1910.119) and is present in quantities greater than or equal to the listed threshold quantity, the PSM standard applies.
- i. **Electrical violations.** If the laboratory analysis indicates that the submitted dust meets the criteria for Class II (See Class II test methodology in appendix E), and if the location where the dust was present falls under any of the Class II location definitions, then 1910.307 will apply. See the Class II definition in 1910.399. If violations involving Class I or III locations are found in the course of conducting an inspection under this NEP, citations must be issued. See the Class I and III definitions in 1910.399.

Equipment, wiring methods, and installations of equipment in hazardous (classified) locations must be: 1) intrinsically safe, 2) approved for the hazardous (classified) location, or 3) safe for the hazardous (classified) location. The meaning of these terms is spelled out in 1910.307(b).

If the employer chooses the third option of providing equipment that is "safe for the hazardous location," then the employer must demonstrate that the equipment is of a type and design that will provide protection from the hazards involved. Compliance with the guidelines contained in the National Electrical Code (NEC) makes up the way, but not the only way, of demonstrating that the electrical equipment is safe for the hazardous location. Necessary documentation includes the location and type of potential electrical ignition sources, the type and condition of electrical equipment located in the area, and information indicating that the equipment is not approved or safe for the location. (See NEC and NFPA 499 for more details.)

- j. **Powered industrial trucks.** For powered industrial truck violations, 1910.178(c)(2)(ii) and (vi)-(ix) and 1910.178(m)(11) apply.

- k. **Welding, cutting, and brazing.** For violations involving welding, cutting, and brazing operations, use 1910.252 General Welding and Cutting. (See (a)(2)(vi)(C), prohibiting cutting and welding in explosive atmospheres, including mixtures of flammable dusts with air), 1910.253 Oxygen-Fuel Gas Welding and Cutting. (See (c)(2)(ii) and (iv), (f)(5)(i)(B)), 1910.254 Arc Welding, and (b)(2)(F)).
- l. **Warning sign violations.** If safety instruction signs are missing on equipment, or at the entrance to places where explosive atmospheres may occur, then citations under 1910.145(c)(3) must be issued.
- m. **Hazard communication violations.** The hazard communication standard, 1910.1200, requires all employers to provide information to their employees about the hazardous chemicals to which they are exposed, by means of a hazard communication program, labels and other forms of warning, material safety data sheets, and information and training. See “hazardous chemicals” definition in 1910.1200(c), which addresses physical hazards. The definition of physical hazards includes flammable solids according to the definition in 1910.1200(c), and employers who do not follow the requirements of this standard will be cited with respect to chemicals that could become combustible dust in the course of normal conditions. The standard requires chemical manufacturers and importers to develop or obtain a material safety data sheet for each hazardous chemical they produce or import according to 1910.1200(g)(1).

CSHOs must evaluate whether there is compliance with 1910.1200(g)(2)-(5) by examining a sample of MSDSs. If MSDSs are not updated when new information becomes available, they are deficient according to 1910.1200(g)(5). If the MSDSs are found deficient with respect to the combustibility or explosibility of the dust being handled, CSHOs must refer to and follow the guidance provided in Program Directive A-150, Hazard Communication.

- n. **Egress violations.** Citations for violations of Subpart E – Means of Egress, 437-002-0040 through 0043 will be issued where violations of these provisions are found.
- o. **Fire protection violations.** Citations for violations of 1910.156 Fire Brigades and 437-002-0187 Portable Fire Extinguishers will be issued where violations of these standards are found. 1910.156 only applies in the context of this NEP if the employer has a fire brigade or industrial fire department. The fire extinguisher provisions of 437-002-0187 do not apply where the employer requires the evacuation of employees in the event of fire, has an emergency action plan meeting the requirements of 437-002-0042, and has a fire prevention plan meeting the requirements of 437-002-0043.
- p. **Bakery equipment violations.** Citations for violations of 1910.263(k)(2) will be issued for fire and explosion hazards in sugar and spice pulverizers.

- q. **Sawmill violations.** Citations for violations of 1910.265(c)(20) Blower, Collecting, and Exhaust Systems.

**Note:** 265(c)(20)(i) can not be cited for defects in the design, construction and maintenance of the blower collecting and exhaust systems, because of the word “should” in the paragraph.

**265(c)(20)(ii – vi) can be cited depending on what is encountered.**

(ii) Collecting systems. All mills containing one or more machines that create dust, shavings, chips, or slivers during a period of time equal to or greater than one-fourth of the working day, shall be equipped with a collecting system. It may be either continuous or automatic, and shall be of sufficient strength and capacity to enable it to remove such refuse from points of operation and immediate vicinities of machines and work areas.

(iii) Exhaust or conveyor systems. Each woodworking machine that creates dust, shavings, chips, or slivers shall be equipped with an exhaust or conveyor system located and adjusted to remove the maximum amount of refuse from the point of operation and immediate vicinity.

(iv) (Reserved)

(v) Dust chambers. Exhaust pipes shall not discharge into an unconfined outside pile if uncontrolled fire or explosion hazards are created. They may empty into settling or dust chambers, designed to prevent the dust or refuse from entering any work area. Such chambers shall be constructed and operated to minimize the danger of fire or dust explosion.

(vi) Hand removal of refuse. Provision for the daily removal of refuse shall be made in all operations not required to have an exhaust system or having refuse too heavy, bulky, or otherwise unsuitable to be handled by the exhaust system.

- r. **Agriculture.** Provisions discussed in this NEP, which may be cited in connection with agricultural operations are the hazard communication standard, 437-004-9800, 437-004-0310(2) and 437-004-1610(1)(b) may also apply to hazards associated with surface dust accumulations. Industries in NAICS 115111 and 115114, Crop Preparation Services for Market, Except Cotton Ginning, are engaged in agricultural operations.

**OUTREACH:** Oregon OSHA will look for avenues to develop outreach programs. These efforts include:

1. Letters and news releases announcing implementation of the Combustible Dust NEP.

2. Seminars on combustible dust topics, tailored for specific audiences, such as employers, employee groups, local trade unions, apprentice programs, and equipment manufacturers. Local fire department staff may be invited to participate. The state fire marshal's assistant will be encouraged to disseminate information.
3. Partnerships and alliances, such as those involving employers within the same industry to share successes and technical information concerning effective means of controlling or eliminating potential dust explosion hazards at their facilities.

**IMIS CODING  
INSTRUCTIONS:**

1. All enforcement activities (inspections, complaints, accidents and referrals) conducted under this NEP must be coded with "DUSTEXPL," entered in the appropriate NEP field/item number on the respective forms.

**The IMIS forms and item #'s where the NEP code "DUSTEXPL" is to be entered:**

OSHA-1 item# 25d.  
OSHA-7 item# 50  
OSHA-36 item# 36  
OSHA-90 item# 30

2. Enforcement activities related to dust hazards under other NEPs and/or LEPs must be coded for all the NEPs and LEPs.
3. All consultation activities (form 20, 30 and 66) conducted in response to this NEP must include "DUSTEXPL" in the NEP field on the forms as well.

**APPENDICES:** The following appendices are provided as guidance for the inspection of facilities handling combustible dust:

Appendix A: NFPA Publications Relevant to Combustible Dust Hazard Controls  
Appendix B: Sample Questions  
Appendix C: Sample Citations  
Appendix D-1 and D-2 Industries that may have combustible dusts  
Appendix E: Combustible Dust Tests Conducted at SLTC  
Appendix F: Example: Combustible Dust Hazard Letter  
Appendix G: References

## Appendix A

### NFPA Publications Relevant to Combustible Dust Hazard Controls

NFPA No.	Title	Current Edition
61	Standard for the Prevention of Fires and Dust Explosions in Agricultural and Food Processing Facilities	2008
68	Guide for Venting of Deflagrations	2007
69	Standard on Explosion Prevention Systems	2008
70	National Electrical Code	2008
77	Recommended Practice on Static Electricity	2007
85	Boiler and Combustion Systems Hazards Code	2007
86	Standard for Ovens and Furnaces	2007
91	Standard for Exhaust Systems for Air Conveying of Vapors, Gases, Mists, and Noncombustible Particulate Solids	2004
484	Standard for Combustible Metals	2006
499	Recommended Practice for the Classification of Combustible Dusts and of Hazardous (Classified) Locations for Electrical Installations in Chemical Process Areas	2008
654	Standard for the Prevention of Fire and Dust Explosions from the Manufacturing, Processing, and Handling of Combustible Particulate Solids	2006
655	Standard for Prevention of Sulfur Fires and Explosions	2007
664	Standard for the Prevention of Fires and Explosions in Wood Processing and Woodworking Facilities	2007

At a minimum, the resource library will have available the hard copies of the latest editions of the following documents:

- a. NFPA 654, Standard for the Prevention of Fires and Dust Explosions from the Manufacturing, Processing, and Handling of Combustible Particulate Solids. (Use this NFPA for most dusts that are not covered under any other NFPA.)
- b. NFPA 484, Standard for Combustible Metals, Metal Powders, and Metal Dusts.
- c. NFPA 664, Standard for the Prevention of Fires and Explosions in Wood Processing and Woodworking Facilities.
- d. NFPA 68, Guide for Venting of Deflagrations.
- e. NFPA 85: Boiler and Combustion Systems Hazards Code.
- f. NFPA 69, Standard on Explosion Prevention Systems.
- g. NFPA 499, Recommended Practice for the Classification of Combustible Dusts and of Hazardous (Classified) Locations for Electrical Installations in Chemical Process Areas. (There must be a classified location established)

- h. NFPA 61 Standard for the Prevention of Fires and Dust Explosions in Agricultural and Food Processing Facilities
- i. FM Global, Data Sheet No. 7-76, Prevention and Mitigation of Combustible Dust Explosions and Fire (2006 Edition).

## Appendix B

### Sample Inspection Questions

(CSHOs may refer to appropriate NFPA standards to develop additional questions.)

What types of combustible dust does the facility have?

(Note: See Table 4.5.2 of NFPA 499 and Table 1 in NMAB 353-3 for additional information on the various types of dust along with their properties)

Does the facility have a housekeeping program with regular cleaning frequencies established for floors and horizontal surfaces, such as ducts, pipes, hoods, ledges, and beams, to minimize dust accumulations within operating areas of the facility? Under the housekeeping program, is the dust on floors, structural members, and other surfaces removed concurrently with operations? Is there dust accumulation of 1/32-inch thick, or greater? For housekeeping violations, what are the dimensions of the room and the dimensions of the area covered with the dust?

Are the dust-containing systems (ducts and dust collectors) designed in a manner that fugitive dusts are not allowed to accumulate in the work area?

Are dust collectors greater than 8 cubic feet in volume located inside of buildings?

If dust explosion hazards exist in rooms, buildings, or other enclosures, do such areas have explosion relief venting distributed over the exterior walls of buildings and enclosures? Is such venting directed to a safe location away from employees?

Does the facility have isolation devices to prevent deflagration propagation between pieces of equipment connected by ductwork?

Does the facility have an ignition control program, such as grounding and bonding and other methods, for dissipating any electrostatic charge that could be generated while transporting the dust through the ductwork?

Does the facility have separator devices to remove foreign materials capable of igniting combustible dusts?

Are electrically-powered cleaning devices, such as sweepers or vacuum cleaners used in dusty areas, approved for the hazard classification, as required under 1910.307(b)?

Is smoking permitted only in safe designated areas?

Are areas where smoking is prohibited posted with "No Smoking" signs?

Is the exhaust from the dust collectors recycled?

Does the dust collector system have spark detection and explosion/deflagration suppression systems? (There are other alternative measures.)

Are all components of the dust collection system constructed of noncombustible materials?

Are ducts designed to maintain sufficient velocity to ensure the transport of both coarse and fine particles?

Are duct systems, dust collectors, and dust-producing machinery bonded and grounded to minimize accumulation of static electrical charge?

Is metal ductwork used?

In areas where a hazardous quantity of dust accumulates or is present in suspension in the air, does all electrical wiring and equipment comply with 1910.307(b) requirements?

Does the facility allow hot work only in safe, designated areas?

Are bulk storage containers constructed of noncombustible materials?

Does the company use methods to dissipate static electricity, such as by bonding and grounding?

Are employees who are involved in operating, maintaining, and supervising facilities that handle combustible dust trained in the hazards of the combustible dust?

Are MSDSs for the chemicals which could become combustible dust under normal operations available to employees?

## Appendix C

### Sample Citations

#### Division 1 Violations.

OAR 437-001-0760(1)(b)(C): The employer did not take all reasonable means to require employees to use all means and methods that were necessary to safely accomplish all work where employees were exposed to a hazard:

(a) SMK Building - There was a dust collector located at the number 1 conveyor system which was located inside the SMK building. (Add thickness levels, lab results, and specifications of dust the collector, if possible.)

(b) Day Bin Building - There was a large dust collector system located in the day bin building that collected dust from the day bins. (Add thickness level, lab results, and specifications of the dust collector, if possible.)

AMONG OTHER METHODS, A FEASIBLE ABATEMENT METHOD TO CORRECT THIS HAZARD IS TO RELOCATE THE DUST COLLECTION SYSTEMS OUTSIDE THE BUILDINGS. ADD ref: NFPA XXX or other reference used. **NOTE: make sure references are not in the AVD language.**

#### Housekeeping Violations

1) 1910.22(a)(1): Place(s) of employment were not kept clean.

(a) Grinding and Polishing Area - The area where aluminum polishing and grinding were performed had explosive aluminum dust located on the pipes in the ceiling, the roof structure, and masonry walls on or about December 17, 20XX. (Add the thickness level and lab results.)

ADD ref: NFPA XXX or other reference used.

2) 1910.22(a)(2): The floor of a workroom was not maintained in a clean condition.

(a) Grinding and Polishing Area – Explosive dust was on floor of the area where aluminum polishing and grinding were performed on or about May 7, 20XX.

ADD ref: NFPA XXX or other reference used.

#### Electrical Violations

**1) 1910.307(c):** Electrical equipment in hazardous (classified) locations was not intrinsically safe, approved for the hazardous (classified) location, or safe for the hazardous (classified) location:

**(a) Robot Polishing and Grinding Area** - Open motor fans, electrical outlet boxes, breaker panels, disconnect switches, normal lighting snap switches, overhead lighting,

robot control panels, stand belt grinders, and portable radios in a Class II, Division 1 location, were not intrinsically safe, approved for a Class II, Division 1 location, or safe for a Class II, Division 1 location, on or about November 16, 20XX.

**(b) Half Round Area** - Electrical equipment including, but not limited to, overhead lights, circuit breaker panels, disconnect switches and outlets, in Class II, Division 1 locations, was not intrinsically safe, approved for a Class II, Division 1, or safe for a Class II, Division 1 location, on or about January 11, 20XX.

**2) 1910.307(c):** Electrical equipment in a hazardous (classified) location was not intrinsically safe, approved for the hazardous (classified) location, or safe for the hazardous (classified) location:

**(a) Mixing Department** - A vacuum used in a Class II, Division 1 location was not intrinsically safe, approved for a Class II, Division 1 location, or safe for a Class II, Division 1 location.

### **Personal Protective Equipment Violations**

**1910.132(a):** Protective equipment was not used when necessary when a hazard of processes or environment capable of causing injury or impairment of the body through physical contact was encountered:

**(a) Aluminum Grinding and Polishing Area** - Employees did not wear easily removable flame-retardant and non-static-generating clothing in an area where combustible aluminum dust was present on or about November 16, 20XX.

AMONG OTHER METHODS, ONE FEASIBLE ABATEMENT METHOD TO CORRECT THIS HAZARD IS TO REQUIRE EMPLOYEES TO WEAR FLAME-RESISTANT, NONSTATIC-GENERATING CLOTHING, INCLUDING SAFETY SHOES THAT ARE STATIC DISSIPATING, IN THIS AREA. ADD ref: NFPA XXX or other reference used.

## Appendix D-1

### Industries with More Frequent and/or High Consequence Combustible Dust Explosions/Fires

SIC	Industry	NAICS
2046	Wet Corn Milling	311221
4911	Electric Services --Establishments engaged in the generation, transmission, and/or distribution of electric energy for sale	221112
2041	Flour and Other Grain Mill Products	311211
2493	Reconstituted Wood Products	321219
2899	Chemicals and Chemical Preparations, Not Elsewhere Classified	325510, 325998
2099	Prepared foods and miscellaneous food specialties, not elsewhere classified	311212
3471	Electroplating, Plating, Polishing, Anodizing, and Coloring	332813
3341	Secondary Smelting and Refining of Nonferrous Metals	331314
2834	Pharmaceutical Preparations	325412
2499	Wood Products, Not Elsewhere Classified	321920, 321219
2421	Sawmills and Planing Mills, General	321113
2062	Cane Sugar Refining	311312
2063	Beet Sugar (Establishments primarily engaged in manufacturing sugar from sugar beets)	311313
3061	Molded, Extruded, and Lathe-Cut Mechanical Rubber Goods	326291
3714	Motor Vehicle Parts and Accessories	336322
3365	Aluminum Foundries	331524

## Appendix D-2

### Industries That May Have Potential for Combustible Dust Explosions/Fires

SIC	Industry	NAICS
0723	Crop preparation services for market, except cotton ginning	115114, 115111
2052	Fresh cookies, crackers, pretzels, and similar "dry" bakery products.	311821
2087	Flavoring extracts, syrups, powders, and related products, not elsewhere classified.	311930
2221	Broadwoven fabric mills, manmade fiber and silk	313210
2262	Finishers of broadwoven fabrics of manmade fiber and silk	313311
2299	Textile goods, not elsewhere classified	313111
2431	Millwork	321911
2434	Wood kitchen cabinets	33711
2439	Structural wood members, not elsewhere classified	321213, 321214
2452	Prefabricated wood buildings and components	321992
2511	Wood household furniture, except upholstered	337122
2591	Drapery hardware and window blinds and shades	337920
2819	Industrial inorganic chemicals, not elsewhere classified	325188, 325998, 331311
2821	Plastic materials, synthetic resins, and nonvulcanizable elastomers	325211
2823	Cellulosic manmade fibers	325221
2841	Soap and other detergents, except specialty cleaners	325611
2851	Paints, varnishes, lacquers, enamels, and allied products	32551
2861	Gum and wood chemicals	325191
3011	Tires and inner tubes	326211
3069	Fabricated rubber products, not elsewhere classified	326299
3081	Unsupported plastics film and sheet	326113
3082	Unsupported plastics profile shapes	326121
3086	Plastics foam products	326140, 326150
3087	Custom compounding of purchased plastics resins	325991
3089	Plastics products, not elsewhere classified	326199
3291	Abrasive products	327910
3313	Alumina and aluminum production and processing	331312
3334	Primary production of aluminum	331312
3354	Aluminum extruded products	331316
3363	Aluminum die-castings	331521
3369	Nonferrous foundries, except aluminum and copper	331528
3398	Metal heat treating	332811
3441	Metal cans	332431
3469	Metal stampings, not elsewhere classified	332116
3479	Coating, engraving, and allied services, not elsewhere classified	332812
3496	Miscellaneous fabricated wire products	332618
3499	Fabricated metal products, not elsewhere classified	332999

<b>SIC</b>	<b>Industry</b>	<b>NAICS</b>
3548	Electric and gas welding and soldering equipment	335129
3644	Noncurrent-carrying wiring devices	335932
3761	Guided missiles and space vehicles	336414
3799	Transportation equipment, Not elsewhere classified	333924
3995	Burial caskets	339995
3999	Manufacturing industries, not elsewhere classified	321999, 325998, 326199
4221	Farm product warehousing and storage	493130
4952	Sanitary treatment facilities	221320
4953	Refuse systems	562920
5093	Scrap and waste materials	423930
5162	Plastics materials and basic forms and shapes	424610

## Appendix E

### Combustible Dust Tests Conducted at Salt Lake Technical Center (SLTC)

1. **Percent through 40 Mesh.** An aliquot of the "as received" material is sieved through a 40 mesh (425 µm) US Standard Testing Sieve. The percent that goes through the sieve is determined using the following steps:
  - a. Weigh a dust aliquot; sieve through 40 mesh.
  - b. Weigh the material passed through the 40 mesh sieve.
  - c. Calculate the percentage that passes through a 40 mesh via:

$$\% \text{ through 40 mesh} = \frac{\text{Grams through 40 mesh} (100)}{\text{Total "as received" aliquot weight}}$$

2. **Percent Moisture Content.** Moisture content is another factor that may have an effect on dust explosibility, and OSHA SLTC makes an initial determination on an aliquot of all dust samples that they receive. Moisture in dust particles raises the ignition temperature. Dusts having more than 5% moisture are dried prior to performing explosibility tests. Drying sample materials to (or less than) the 5% moisture content level is a standardized test protocol. The moisture content of the sieved material is determined by measuring the weight loss after drying. This test method must be modified when the materials being tested would be degraded at 75°C. Percent moisture content is determined as follows.
  - a. Weigh crucibles and aliquots of material which passed through a 40 mesh sieve.
  - b. Dry for twenty-four hours in a drying oven set at 75°C. Then reweigh the material.
  - c. Calculate the moisture content as:

$$\% \text{ Moisture Content} = \frac{(\text{Wet Sample Weight} - \text{Dry Sample Weight})(100)}{\text{Wet Sample weight}}$$

Note: "Moisture in dust particles raises the ignition temperature of the dust because of the heat absorbed during heating and vaporization of the moisture. The moisture in the air surrounding a dust particle has no significant effect on the course of a deflagration once ignition has occurred. There is, however, a direct relationship between moisture content and minimum energy required for ignition, minimum explosive concentration, maximum pressure, and maximum rate of pressure rise. For example, the ignition temperature of cornstarch may increase as much as 122°F, with an increase of moisture content from 1.6 percent to 12.5 percent. As a practical matter, however, moisture content cannot be considered an effective explosion preventive, since most ignition sources provide more than enough heat to vaporize the moisture and to ignite the dust. In order for moisture to prevent ignition of dust by common sources, the dust would have to be so damp that a cloud could not be formed." (Source: Fire Protection Handbook, 19th Edition.)

3. **Percent Combustible Material. (Used only with grain handling facilities)** Percent combustible material is determined as follows:
- Weigh crucibles and aliquots of material which passed through a 40 mesh sieve.
  - Place ash samples, uncovered, for one hour at 600°C in a muffle furnace. Then reweigh the residue.
  - Calculate the combustible material as:

$$\% \text{ Combustible Material} = \frac{(\text{Wet Sample Weight} - \text{Ash Weight}) (100)}{\text{Wet Sample Weight}}$$

4. **Percent Combustible Dust. (Used only with grain handling facilities)** Percent combustible dust is the product of the percent of material which went through a 40 mesh sieve and the percent combustible material. This is calculated as follows:

$$\% \text{ combustible dust} = (\% \text{ through 40 mesh})(\% \text{ combustible material})$$

(Be aware of the distinction between combustible material and combustible dust.)

5. **Maximum Normalized Rate of Pressure rise (dP/dt) – Kst test**

Kst is the Deflagration Index for dusts, and the Kst test results provide an indication of the severity of a dust explosion. The larger the value for Kst, the more severe is the explosion (See Table below). Kst is essentially the maximum rate of pressure rise generated when dust is tested in a confined enclosure. Kst provides the best “single number” estimate of the anticipated behavior of a dust deflagration.

Dust explosion class	Kst (bar.m/s)	Characteristic
St 0	0	No explosion
St 1	>0 and <=200	Weak explosion
St 2	>200 and <=300	Strong explosion
St 3	>300	Very strong explosion

Approximately 300 grams of "as received" sample material are needed for the Kst test. In this test, dust is suspended in the 20-liter explosibility testing chamber (shown in Figure 1) and is ignited using a chemical igniter. The 20-liter explosibility testing chamber determines maximum pressure and rate of pressure rise if the sample explodes. These parameters are used to determine the maximum normalized rate of pressure rise (Kst). Kst is calculated with the following formula:

$$Kst = (dP/dt)_{\max} V^{1/3}$$

Where: (dP/dt) max = the maximum rate of pressure rise

V = the volume of the testing chamber:

The test involves the following steps:

- a. The sample dust is suspended in a 20-liter explosion chamber. (Use 2500 J Sobbe igniters if using the Bureau of Mines test chamber.)
  - b. The dust is tested "as received" (except drying, if the moisture content is greater than 5%).
  - c. Test at three to five dust concentrations, from 500 g/m<sup>3</sup> to about 2500 g/m<sup>3</sup>, plotting the found maximum normalized dp/dt values versus dust concentration, and reporting the highest value from the plateau of the plot.
6. **Minimum Explosible Concentration.** Minimum explosible concentration (MEC) of the sample is determined by suspending the sample in a 20-liter explosibility testing chamber and ignited with a 2500-joule chemical igniter. MEC is the lower concentration limit of explosibility for the dust. This limit is determined using test material that has been sieved through a 40-mesh sieve (425 μm particle size), dried, suspended in a 20-liter explosibility testing chamber. Approximately 200 grams of material with a particle size of 425 μm or less are needed for the MEC tests. Some analytical details include:
- a. Use test material that has been sieved through 40-mesh screen.
  - b. Use material which has been either dried in an oven at 75°C overnight (if the moisture content is greater than 5%) or kept in a desiccator.
  - c. Use 2500 J igniters.
  - d. Plot both the dp/dt and pressure ratio versus concentration. The minimum explosible concentration is where the K<sub>st</sub> is greater than or equal to 1.5 and the pressure ratio is greater than or equal to 2.

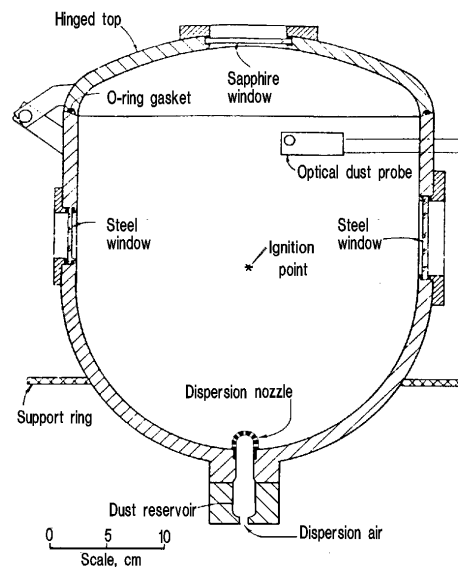

**Figure 1: 20-Liter Explosibility Test Chamber**

## 7. Class II Test

National Materials Advisory Board (NMAB) 353-3-80, *Classification of Combustible Dusts in Accordance with the National Electrical Code*, defines dusts having Ignition Sensitivity (IS) greater than or equal to 0.2 or Explosion Severity (ES) greater than or equal to 0.5 to be appreciable explosion hazards requiring electrical equipment suitable for Class II locations. This document is listed as a reference document in Appendix A to Subpart S of 1910. Dusts whose explosibility parameters fall below these limits are generally considered to be weak explosion hazards and need only general purpose electrical equipment.

Approximately 1 liter bulk volume with particle size less than 75 µm (200 mesh) are necessary to determine the Class II dust classification. SLTC will only characterize a sample sufficiently to prove (or disprove) that the sample meets the definition for class dusts, based on results of the ES or the IS.

ES tests are made by suspending dust in a Hartmann stainless steel explosion chamber and igniting it with an electrical spark. If the sample explodes, the maximum pressure and rate of pressure rise developed by the explosion are recorded. ES is the product of the maximum explosion pressure and the maximum rate of pressure rise, normalized to Pittsburgh coal dust. Mathematically it is defined as:

$$E.S. = \frac{(PxR) \text{ Sample}}{(PxR) \text{ Pittsburgh Coal}}$$

Where

P = Maximum Explosion Pressure

R = Maximum Rate of Pressure Rise

The IS is the product of the minimum ignition temperature, minimum ignition energy, and the minimum explosion concentration normalized to Pittsburgh coal dust. It is expressed mathematically as:

$$I.S. = \frac{(T \times E \times C) \text{ Pittsburgh Coal}}{(T \times E \times C) \text{ Sample}}$$

Where T = Minimum Ignition Temperature

E = Minimum Ignition Energy

C = Minimum Explosion Concentration

If ES is greater than or equal to 0.5 further tests are suspended and the sample is reported to be a Class II dust. If no explosion occurs the Class II dust testing will be terminated.

## 8. Resistivity.

The resistivity or specific resistance is defined as the electrical resistance of a material of unit cross section and of unit length. Resistivity must be measured under conditions comparable to those to which the dust is present in the workplace. The test for resistivity

must be conducted at the highest voltage to which the dust is exposed, to assure that high resistivity surface coatings don't break down when subjected to a voltage gradient in the equipment that may be higher than that used in these analyses. If the sample is combustible and conductive, then a Class II, Division 1 location is specified.

Based on the classification of dusts using the NMAB 353-3-80 resistivity guidelines, explosible dusts are classified into Groups E, F, and G through the values of electrical resistivity as follows:

Group E,  $\rho \leq 10^2$  ohm-cm

Group F,  $10^2 < \rho \leq 10^8$  ohm-cm

Group G,  $\rho > 10^8$  ohm-cm

According to the definition for a Class II, Division 1 location as found in 1910.399, the electrical conductive nature of the dust is one of the criteria to determine if it is necessary that equipment in a dust location be approved for Class II, Division 1 location. Where group E dusts are present in hazardous quantities, there are only Division 1 locations. The NEC does not recognize any Division 2 locations for such dusts. (See NFPA 499 or NEC).

**9. Minimum Ignition Energy (MIE).**

The minimum ignition energy (MIE) of the sample is determined by suspending the sample in a Hartmann Lucite explosion chamber. To determine the MIE, the energy of the electrical spark used to ignite the dust is varied until the MIE is determined.

**10. Minimum Ignition Temperature (MIT)**

Minimum ignition temperature (MIT) is determined by using the Dodbert-Greenwald furnace. Dust is discharged through this furnace at various temperatures. The lowest temperature that ignites the dust is considered to be the MIT.

## Appendix F

### Example: Combustible Dust Hazard Letter

During a recent inspection of your facility combustible dust hazards were evaluated. At the time of the inspection, no violations were noted. The intent of this letter is to inform you of the hazards of combustible dust in the event that your process, equipment design, or work practices change and create a combustible dust hazard.

In order to evaluate combustible dust hazards, the following are critical:

- Housekeeping – dust accumulation as little as 1/32 of an inch, depending on the combustibility of the material, can be of concern.
- Particle size of the dust – generally speaking, the finer the particulate, the more likely it is to become combustible.
- Moisture content – the wetter the dust, the less likely it is to be combustible.
- Ignition source – if conditions are right for a combustible dust explosion, possible ignition sources are vast. These would include welding, electrical outlets, heat sources, static energy, industrial vehicles, or even dropping a metal tool on a hard surface.
- Combustibility of the dust – many kinds of dust are combustible. These range from wood dust to metal dust.
- An event that causes accumulated dust to become airborne, or a process which causes dust to be airborne in excess of the minimum explosive concentration (MEC).

Dusts that are combustible include, but are not limited to:

- Metal dust such as aluminum and magnesium
- Wood dust
- Coal and other carbon dusts
- Plastic dust and additives
- Biosolids
- Other organic dust such as sugar, flour, paper, soap, hay, and grain.
- Certain textile materials

Good housekeeping is your best defense to protect your facility from a combustible dust explosion. Keeping surfaces free of dust, including beams and other structural members, is critical. Cleaning methods should be those which do not cause dust to become airborne. Using compressed air to remove accumulated dust is a very poor choice. Vacuuming, or when feasible, using water to wash dust off surfaces is a good choice. Vacuums should be appropriately rated for combustible dust locations.

The use of engineering controls or specialized equipment can greatly reduce the possibility of a combustible dust explosion. The following considerations can create a safer work environment where combustible dust is possible:

- Ensure that dust collection equipment is properly installed and located. Dust collection equipment should not be located within your building but should be outside. Blast doors should be installed so that if they should explode, they aren't directed at sensitive equipment, other dust collection equipment, ignition sources, or worker stations.
- Dust-tight enclosures are those that are constructed so that dust will not enter.

- Dust-ignition proof equipment is that which is enclosed in a manner that excludes dust and does not permit arcs, sparks, or heat inside of the enclosure to cause ignition of exterior accumulations or airborne dust, on or near the enclosure.
- Deflagration suppression is a technique of detecting and arresting combustion in a confined space while the combustion is still in its incipient stage, thus preventing the development of pressures that could cause an explosion.

Attached to this hazard letter is a hazard alert on combustible dust. It contains further information and sources on combustible dust hazards. If you need assistance, Oregon OSHA Consultation is a service available, and is confidential and free of charge.

## Appendix G: References

- A. [OSHA Directive Number: CPL 03-00-008, Combustible Dust National Emphasis Program \(Reissued\).](#)
- B. [Oregon OSHA Field Inspection Reference Manual \(FIRM\).](#)
- C. [Oregon OSHA Program Directive A-189, Grain Handling Facilities, 1910.272.](#)
- D. [Oregon OSHA Program Directive A-212, Electric Power Generation, Transmission, and Distribution Facilities.](#)
- E. Safety and Health Information Bulletin (SHIB)--Improper Installation of Wood Dust Collectors in the Woodworking Industry—May 2, 1997.
- F. SHIB--Combustible Dust in Industry: Preventing and Mitigating the Effects of Fire and Explosions—July 31, 2005.
- G. 1910.399--Definitions applicable to Subpart S—Electrical.
- H. NFPA 61, Standard for the Prevention of Fires and Dust Explosions in Agricultural and Food Processing Facilities (2002 Edition).
- I. NFPA 68, Guide for Venting of Deflagrations (2002 Edition).
- J. NFPA 69, Standard on Explosion Prevention Systems (2002 Edition).
- K. NFPA 70, National Electrical Code (2005).
- L. NFPA 77, Recommended Practice on Static Electricity.
- M. NFPA 86, Standard for Ovens and Furnaces.
- N. NFPA 120, Standard for Fire Prevention and Control in Coal Mines.
- O. NFPA 91, Standard for Exhaust Systems for Air Conveying of Vapors, Gases, Mists, and Noncombustible Particulate Solids (2004 Edition).
- P. NFPA 484, Standard for Combustible Metals (2006 Edition).
- Q. NFPA 499, Recommended Practice for the Classification of Combustible Dusts and of Hazardous (Classified) Locations for Electrical Installations in Chemicals Process Areas (2004 Edition).
- R. NFPA 654, Standard for the Prevention of Fires and Dust Explosions from the Manufacturing, Processing, and Handling of Combustible Particulate Solids (2006 Edition).
- S. NFPA 664, Standard for the Prevention of Fires and Explosions in Wood Processing and Woodworking Facilities (2007 Edition).

- T. NFPA 2113, Standard on Selection, Care, Use and Maintenance of Flame-Resistant Garments for Protection of Industrial Personnel Against Flash Fire.
- U. ASTM E1226 – 05, Standard Test Method for Pressure and Rate of Pressure Rise for Combustible Dusts.
- V. ASTM E1515, Standard Test Method for Minimum Explosible Concentration of Combustible Dusts.
- W. FM Global, Data Sheet No. 7-76, Prevention and Mitigation of Combustible Dust Explosions and Fire (2006 Edition).
- X. National Materials Advisory Board (NMAB) 353-3-80, Classification of Combustible Dusts in Accordance with the National Electrical Code.
- Y. NFPA 85, Boiler and Combustion Systems Hazards Code (2007 Edition).