

J

SAFETY COLOR CODE FOR MARKING PHYSICAL HAZARDS / SPECIFICATIONS FOR ACCIDENT PREVENTION SIGNS & TAGS

(iii) Stop. Emergency stop bars on hazardous machines such as rubber mills, wire blocks, flat work ironers, etc., shall be red. Stop buttons or electrical switches which letters or other markings appear, used for emergency stopping of machinery shall be red.

(2) (Reserved)

(3) Yellow. Yellow shall be the basic color for designating caution and for marking physical hazards such as: Striking against, stumbling, falling, tripping, and “caught in between.”

(39 FR 23502, June 27, 1974, as amended at 43 FR 49748, Oct. 24, 1978; 49 FR 5322, Feb. 10, 1984)

Stat. Auth.: ORS 654.025(2) and ORS 656.726(4).

Stats. Implemented: ORS 654.001 through 654.295.

Hist: OR-OSHA Admin. Order 13-1992, f. 12/7/92, ef. 2/1/93.

OR-OSHA Admin. Order 4-1997, f. 4/2/97, ef. 4/2/97.

OR-OSHA Admin. Order 7-2008, f. 5/30/08, ef. 5/30/08.

§1910.145 Specifications for Accident Prevention Signs and Tags.

(a) Scope.

(1) These specifications apply to the design, application, and use of signs or symbols (as included in paragraphs (c) through (e) of this section) intended to indicate and, insofar as possible, to define specific hazards of a nature such that failure to designate them may lead to accidental injury to workers or the public, or both, or to property damage. These specifications are intended to cover all safety signs except those designed for streets, highways, railroads, and marine regulations. These specifications do not apply to plant bulletin boards or to safety posters.

(2) All new signs and replacements of old signs shall be in accordance with these specifications.

(b) Definitions. As used in this section, the word “sign” refers to a surface on prepared for the warning of, or safety instructions of, industrial workers or members of the public who may be exposed to hazards. Excluded from this definition, however, are news releases, displays commonly known as safety posters, and bulletins used for employee education.

**ADDITIONAL OREGON RULES FOR
ACCIDENT PREVENTION SIGNS &
TAGS / SPECIFICATIONS FOR
ACCIDENT PREVENTION SIGNS &
TAGS**

J

437-002-0145 Additional Oregon Rules for Accident Prevention Signs and Tags.

Warning Devices. *Warning signs, danger signs, warning flags, warning lights, or similar devices shall be conspicuously posted at all locations where existing conditions not otherwise adequately guarded warrant their use.*

Stat. Auth.: ORS 654.025(2) and 656.726(3).
Hist: WCB No. 1-1967, f. 1/12/67, ef. 1/15/67.
OR-OSHA Admin. Order 6-1994, f. 9/30/94, ef. 9/30/94.

(c) Classification of signs according to use.

(1) Danger signs.

(i) There shall be no variation in the type of design of signs posted to warn of specific dangers and radiation hazards.

(ii) All employees shall be instructed that danger signs indicate immediate danger and that special precautions are necessary.

(2) Caution signs.

(i) Caution signs shall be used only to warn against potential hazards or to caution against unsafe practices.

(ii) All employees shall be instructed that caution signs indicate a possible hazard against which proper precaution should be taken.

(3) Safety instruction signs. Safety instruction signs shall be used where there is a need for general instructions and suggestions relative to safety measures.

(d) Sign design.

(1) Design features. All signs shall be furnished with rounded or blunt corners and shall be free from sharp edges, burrs, splinters, or other sharp projections. The ends or heads of bolts or other fastening devices shall be located in such a way that they do not constitute a hazard.

(2) Danger signs. The colors red, black, and white shall be those of opaque glossy samples as specified in Table 1 of Fundamental Specification of Safety Colors for CIE Standard Source "C," American National Standard Z53.1-1967, which is incorporated by reference as specified in §1910.6.

(3) (Reserved)

(4) Caution signs. Standard color of the background shall be yellow; and the panel, black with yellow letters. Any letters used against the yellow background shall be black. The colors shall be those of opaque glossy samples as specified in Table 1 of American National Standard Z53.1-1967.

(5) (Reserved)

(6) Safety instruction signs. Standard color of the background shall be white; and the panel, green with white letters. Any letters used against the white background shall be black. The colors shall be those of opaque glossy samples as specified in Table 1 of American National Standard, Z53.1-1967.

(7) (Reserved)

(8) (Reserved)

(9) (Reserved)

(10) Slow-moving vehicle emblem. This emblem (see Figure J-7) consists of a fluorescent yellow-orange triangle with a dark red reflective border. The yellow-orange fluorescent triangle is a highly visible color for daylight exposure. The reflective border defines the shape of the fluorescent color in daylight and creates a hollow red triangle in the path of motor vehicle headlights at night. The emblem is intended as a unique identification for, and it shall be used only on, vehicles which by design move slowly (25 mph or less) on the public roads. The emblem is not a clearance marker for wide machinery nor is it intended to replace required lighting or marking of slow-moving vehicles. Neither the color film pattern and its dimensions nor the backing shall be altered to permit use of advertising or other markings. The material, location, mounting, etc., of the emblem shall be in accordance with the American Society of Agricultural Engineers Emblem for Identifying Slow-Moving Vehicles, ASAE R276, 1967, or ASAE S276.2 (ANSI B114.1-1971), which are incorporated by reference as specified in

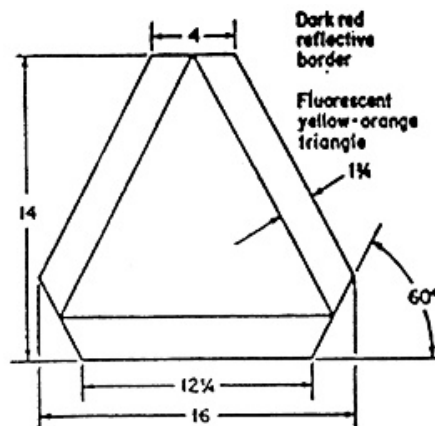

§1910.6.

Figure J-7. Slow-Moving Vehicle Emblem

Note: All dimensions are in inches.

SPECIFICATIONS FOR ACCIDENT PREVENTION SIGNS & TAGS

J

(e) Sign wordings.

(1) (Reserved)

(2) Nature of wording. The wording of any sign should be easily read and concise. The sign should contain sufficient information to be easily understood. The wording should make a positive, rather than negative suggestion and should be accurate in fact.

(3) (Reserved)

(4) Biological hazard signs. The biological hazard warning shall be used to signify the actual or potential presence of a biohazard and to identify equipment, containers, rooms, materials, experimental animals, or combinations thereof, which contain, or are contaminated with, viable hazardous agents. For the purpose of this subparagraph the term “biological hazard,” or “biohazard,” shall include only those infectious agents presenting a risk or potential risk to the well-being of man.

(f) Accident prevention tags.

(1) Scope and application.

(i) This paragraph (f) applies to all accident prevention tags used to identify hazardous conditions and provide a message to employees with respect to hazardous conditions as set forth in paragraph (f)(3) of this section, or to meet the specific tagging requirements of other OSHA standards.

(ii) This paragraph (f) does not apply to construction, maritime or agriculture.

(2) Definitions.

Biological hazard or **BIOHAZARD** means those infectious agents presenting a risk of death, injury or illness to employees.

Major message means that portion of a tag’s inscription that is more specific than the signal word and that indicates the specific hazardous condition or the instruction to be communicated to the employee. Examples include: “**High Voltage**,” “**Close Clearance**,” “**Do Not Start**,” or “**Do Not Use**” or a corresponding pictograph used with a written text or alone.

Pictograph means a pictorial representation used to identify a hazardous condition or to convey a safety instruction.

Signal word means that portion of a tag’s inscription that contains the word or words that are intended to capture the employee’s immediate attention.

Tag means a device usually made of card, paper, pasteboard, plastic or other material used to identify a hazardous condition.

(3) Use. Tags shall be used as a means to prevent accidental injury or illness to employees who are exposed to hazardous or potentially hazardous conditions, equipment or operations which are out of the ordinary, unexpected or not readily apparent. Tags shall be used until such time as the identified hazard is eliminated or the hazardous operation is completed. Tags need not be used where signs, guarding or other positive means of protection are being used.

(4) General tag criteria. All required tags shall meet the following criteria:

(i) Tags shall contain a signal word and a major message.

(A) The signal word shall be either “**Danger,**” “**Caution,**” or “**Biological Hazard,**” “**BIOHAZARD,**” or the biological hazard symbol.

(B) The major message shall indicate the specific hazardous condition or the instruction to be communicated to the employee.

(ii) The signal word shall be readable at a minimum distance of 5 feet (1.52 m) or such greater distance as warranted by the hazard.

(iii) The tag’s major message shall be presented in either pictographs, written text or both.

(iv) The signal word and the major message shall be understandable to all employees who may be exposed to the identified hazard.

(v) All employees shall be informed as to the meaning of the various tags used throughout the workplace and what special precautions are necessary.

(vi) Tags shall be affixed as close as safely possible to their respective hazards by a positive means such as string, wire, or adhesive that prevents their loss or unintentional removal.

(5) Danger tags. Danger tags shall be used in major hazard situations where an immediate hazard presents a threat of death or serious injury to employees. Danger tags shall be used only in these situations.

(6) Caution tags. Caution tags shall be used in minor hazard situations where a non-immediate or potential hazard or unsafe practice presents a lesser threat of employee injury. Caution tags shall be used only in these situations.

(7) Warning tags. Warning tags may be used to represent a hazard level between “Caution” and “Danger,” instead of the required “Caution” tag, provided that they have a signal word of “Warning,” an appropriate major message, and otherwise meet the general tag criteria of paragraph (f)(4) of this section.

(8) Biological hazard tags.

(i) Biological hazard tags shall be used to identify the actual or potential presence of a biological hazard and to identify equipment, containers, rooms, experimental animals, or combinations thereof, that contain or are contaminated with hazardous biological agents.

(ii) The symbol design for biological hazard tags shall conform to the design shown below:



**Biological Hazard Symbol
Configuration**

(9) Other tags. Other tags may be used in addition to those required by this paragraph (f), or in other situations where this paragraph (f) does not require tags, provided that they do not detract from the impact or visibility of the signal word and major messages of any required tag.

(Approved by the Office of Management and Budget under control number 1218-0132)

Stat. Auth.: ORS 654.025(2) and ORS 656.726(3).

Stats. Implemented: ORS 654.001 through 654.295.

Hist: OR-OSHA Admin. Order 13-1992, f. 12/7/92, ef. 2/1/93.
OR-OSHA Admin. Order 4-1997, f. 4/2/97, ef. 4/2/97.

APPENDICES TO §1910.145(f), ACCIDENT PREVENTION TAGS

Appendix A to §1910.145(f) – Recommended Color Coding

While the standard does not specifically mandate colors to be used on accident prevention tags, the following color scheme is recommended by OSHA for meeting the requirements of this section:

“**DANGER**” – Red, or predominantly red, with lettering or symbols in a contrasting color.

“**CAUTION**” – Yellow, or predominantly yellow, with lettering or symbols in a contrasting color.

“**WARNING**” – Orange, or predominantly orange, with lettering or symbols in a contrasting color.

“**BIOLOGICAL HAZARD**” – Fluorescent orange or orange-red, or predominantly so, with lettering or symbols in a contrasting color.

Stat. Auth.: ORS 654.025(2) and ORS 656.726(3).

Hist: OR-OSHA Admin. Order 13-1992, f. 12/7/92, ef. 2/1/93.

REFERENCES FOR FURTHER INFORMATION

J

Appendix B to §1910.145(f) – References for Further Information

The following references provide information which can be helpful in understanding the requirements contained in various sections of the standard:

1. Bresnahan, Thomas F., and Bryk, Joseph, "The Hazard Association Values of Accident Prevention Signs," Journal of American Society of Safety Engineers; January 1975.
2. Dreyfuss, H., Symbol Sourcebook, McGraw Hill; New York, NY, 1972.
3. Glass, R.A. and others, Some Criteria for Colors and Signs in Workplaces, National Bureau of Standards, Washington, DC, 1983.
4. Graphic Symbols for Public Areas and Occupational Environments, Treasury Board of Canada, Ottawa, Canada, July 1980.
5. Howett, G.L., Size of Letters Required for Visibility as a Function of Viewing Distance and Observer Acuity, National Bureau of Standards, Washington, DC, July 1983.
6. Lerner, N.D. and Collins, B.L., The Assessment of Safety Symbol Understandability by Different Testing Methods, National Bureau of Standards, Washington, DC, 1980.
7. Lerner, N.D. and Collins, B.L., Workplace Safety Symbols, National Bureau of Standards, Washington, DC, 1980.
8. Modley, R. and Meyers, W.R., Handbook of Pictorial Symbols, Dover Publication, New York, NY, 1976.
9. Product Safety Signs and Labels, FMC Corporation, Santa Clara, CA, 1978.
10. Safety Color Coding for Marking Physical Hazards, Z53.1, American National Standards Institute, New York, NY, 1979.
11. Signs and Symbols for the Occupational Environment, Can. 3-Z-321-77, Canadian Standards Association, Ottawa, September 1977.
12. Symbols for Industrial Safety, National Bureau of Standards, Washington, DC, April 1982.
13. Symbol Signs, U.S. Department of Transportation, Washington, DC, November 1974.

(39 FR 23502, June 27, 1974, as amended at 43 FR 49749, Oct. 24, 1978; 43 FR 51759, Nov. 7, 1978; 49 FR 5322, Feb. 10, 1984; 51 FR 33260, Sept. 19, 1986)

Stat. Auth.: ORS 654.025(2) and ORS 656.726(3).

Hist: OR-OSHA Admin. Order 13-1992, f. 12/7/92, ef. 2/1/93.

