

TABLE OF CONTENTS

1926.1050	Scope, application, and definitions applicable to this subdivision	X-1
1926.1051	General requirements	X-4
1926.1052	Stairways	X-5
1926.1053	Ladders	X-8
<i>437-003-0065</i>	<i>Extension ladders</i>	X-15
1926.1054 – 1926.1059	(Reserved)	X-15
1926.1060	Training requirements	X-16
Appendix A to Subdivision X – Ladders (non-mandatory guidelines)		X-17

SCOPE, APPLICATION, & DEFINITIONS APPLICABLE TO THIS SUBDIVISION

X

SUBDIVISION X

STAIRWAYS AND LADDERS

Authority: Section 107, Contract Work Hours and Safety Standards Act (Construction Safety Act)(40 U.S.C. 333); Secs. 4, 6, 8, Occupational Safety and Health Act of 1970 (29 U.S.C. 653, 655, 657); Secretary of Labor's Order Nos. 1-90 (55 FR 9033), 5-2007 (72 FR 31159); and 29 CFR part 1911.

§1926.1050 Scope, Application, and Definitions Applicable to this Subdivision.

(a) Scope and Application. This subpart applies to all stairways and ladders used in construction, alteration, repair (including painting and decorating), and demolition workplaces covered under 29 CFR part 1926, and also sets forth, in specified circumstances, when ladders and stairways are required to be provided. Additional requirements for ladders used on or with scaffolds are contained in subpart L – Scaffolds. This subpart does not apply to integral components of equipment covered by subpart CC. Subpart CC exclusively sets forth the circumstances when ladders and stairways must be provided on equipment covered by subpart CC.

(b) Definitions.

Cleat means a ladder crosspiece of rectangular cross section placed on edge upon which a person may step while ascending or descending a ladder.

Double-cleat ladder means a ladder similar in construction to a single-cleat ladder, but with a center rail to allow simultaneous two-way traffic for employees ascending or descending.

Equivalent means alternative designs, materials, or methods that the employer can demonstrate will provide an equal or greater degree of safety for employees than the method or item specified in the standard.

Extension trestle ladder means a self-supporting portable ladder, adjustable in length, consisting of a trestle ladder base and a vertically adjustable extension section, with a suitable means for locking the ladders together.

Failure means load refusal, breakage, or separation of component parts. Load refusal is the point where the structural members lose their ability to carry the loads.

X SCOPE, APPLICATION, & DEFINITIONS APPLICABLE TO THIS SUBDIVISION

Fixed ladder means a ladder that cannot be readily moved or carried because it is an integral part of a building or structure. A **side-step fixed ladder** is a fixed ladder that requires a person getting off at the top to step to the side of the ladder side rails to reach the landing. A **through fixed ladder** is a fixed ladder that requires a person getting off at the top to step between the side rails of the ladder to reach the landing.

Handrail means a rail used to provide employees with a handhold for support.

Individual-rung/step ladders means ladders without a side rail or center rail support. Such ladders are made by mounting individual steps or rungs directly to the side or wall of the structure.

Job-made ladder means a ladder that is fabricated by employees, typically at the construction site, and is not commercially manufactured. This definition does not apply to any individual-rung/step ladders.

Ladder stand. A mobile fixed size self-supporting ladder consisting of a wide flat tread ladder in the form of stairs. The assembly may include handrails.

Lower levels means those areas to which an employee can fall from a stairway or ladder. Such areas include ground levels, floors, roofs, ramps, runways, excavations, pits, tanks, material, water, equipment, and similar surfaces. It does not include the surface from which the employee falls.

Maximum intended load means the total load of all employees, equipment, tools, materials, transmitted loads, and other loads anticipated to be applied to a ladder component at any one time.

Nosing means that portion of a tread projecting beyond the face of the riser immediately below.

Point of access means all areas used by employees for work-related passage from one area or level to another. Such open areas include doorways, passageways, stairway openings, studded walls, and various other permanent or temporary openings used for such travel.

Portable ladder means a ladder that can be readily moved or carried.

Riser height means the vertical distance from the top of a tread to the top of the next higher tread or platform/landing or the distance from the top of a platform/landing to the top of the next higher tread or platform/landing.

Side-step fixed ladder. See "Fixed ladder."

SCOPE, APPLICATION, & DEFINITIONS APPLICABLE TO THIS SUBDIVISION

X

Single-cleat ladder means a ladder consisting of a pair of side rails, connected together by cleats, rungs, or steps.

Single-rail ladder means a portable ladder with rungs, cleats, or steps mounted on a single rail instead of the normal two rails used on most other ladders.

Spiral stairway means a series of steps attached to a vertical pole and progressing upward in a winding fashion within a cylindrical space.

Stairrail system means a vertical barrier erected along the unprotected sides and edges of a stairway to prevent employees from falling to lower levels. The top surface of a stairrail system may also be a “handrail.”

Step stool (ladder type) means a self-supporting, foldable, portable ladder, non-adjustable in length, 32 inches or less in overall size, with flat steps and without a pail shelf, designed to be climbed on the ladder top cap as well as all steps. The side rails may continue above the top cap.

Through fixed ladder. See “Fixed ladder.”

Tread depth means the horizontal distance from front to back of a tread (excluding nosing, if any).

Unprotected sides and edges means any side or edge (except at entrances to points of access) of a stairway where there is no stairrail system or wall 36 inches (.9 m) or more in height, and any side or edge (except at entrances to points of access) of a stairway landing, or ladder platform where there is no wall or guardrail system 39 inches (1 m) or more in height.

Stat. Auth.: ORS 654.025(2) and 656.726(4).

Stats. Implemented: ORS 654.001 through 654.295.

Hist: OR-OSHA Admin. Order 6-1991, f. 3/18/91, ef. 4/15/91.
OR-OSHA Admin. Order 3-2000, f. 2/8/00, ef. 2/8/00.
OR-OSHA Admin. Order 1-2011, f. 2/9/11. Ef. 2/9/11.

X GENERAL REQUIREMENTS

§1926.1051 General Requirements.

(a) A stairway or ladder shall be provided at all personnel points of access where there is a break in elevation of 19 inches (48 cm) or more, and no ramp, runway, sloped embankment, or personnel hoist is provided.

(1) Employees shall not use any spiral stairways that will not be a permanent part of the structure on which construction work is being performed.

(2) A double-cleated ladder or two or more separate ladders shall be provided when ladders are the only mean of access or exit from a working area for 25 or more employees, or when a ladder is to serve simultaneous two-way traffic.

(3) When a building or structure has only one point of access between levels, that point of access shall be kept clear to permit free passage of employees. When work must be performed or equipment must be used such that free passage at that point of access is restricted, a second point of access shall be provided and used.

(4) When a building or structure has two or more points of access between levels, at least one point of access shall be kept clear to permit free passage of employees.

(b) Employers shall provide and install all stairway and ladder fall protection systems required by this subdivision and shall comply with all other pertinent requirements of this subdivision before employees begin the work that necessitates the installation and use of stairways, ladders, and their respective fall protection systems.

Stat. Auth.: ORS 654.025(2) and 656.726(3).
Hist: OR-OSHA Admin. Order 6-1991, f. 3/18/91, ef. 4/15/91.

§1926.1052 Stairways.

(a) General. The following requirements apply to all stairways as indicated:

- (1) Stairways that will not be a permanent part of the structure on which construction work is being performed shall have landings of not less than 30 inches (76 cm) in the direction of travel and extend at least 22 inches (56 cm) in width at every 12 feet (3.7 m) or less of vertical rise.
- (2) Stairs shall be installed between 30° and 50° from horizontal.
- (3) Riser height and tread depth shall be uniform within each flight of stairs, including any foundation structure used as one or more treads of the stairs. Variations in riser height or tread depth shall not be over 1/4-inch (0.6 cm) in any stairway system.
- (4) Where doors or gates open directly on a stairway, a platform shall be provided, and the swing of the door shall not reduce the effective width of the platform to less than 20 inches (51 cm).
- (5) Metal pan landings and metal pan treads, when used, shall be secured in place before filling with concrete or other material.
- (6) All parts of stairways shall be free of hazardous projections, such as protruding nails.
- (7) Slippery conditions on stairways shall be eliminated before the stairways are used to reach other levels.

(b) Temporary service. The following requirements apply to all stairways as indicated:

- (1) Except during stairway construction, foot traffic is prohibited on stairways with pan stairs where the treads and/or landings are to be filled in with concrete or other material at a later date, unless the stairs are temporarily fitted with wood or other solid material at least to the top edge of each pan. Such temporary treads and landings shall be replaced when worn below the level of the top edge of the pan.
- (2) Except during stairway construction, foot traffic is prohibited on skeleton metal stairs where permanent treads and/or landings are to be installed at a later date, unless the stairs are fitted with secured temporary treads and landings long enough to cover the entire tread and/or landing area.
- (3) Treads for temporary service shall be made of wood or other solid material, and shall be installed the full width and depth of the stair.

(c) **Stairrails and handrails.** The following requirements apply to all stairways as indicated:

(1) Stairways having four or more risers or rising more than 30 inches (76 cm), whichever is less, shall be equipped with:

Oregon Note: Count each vertical distance of the overall vertical height to determine the total number of risers.

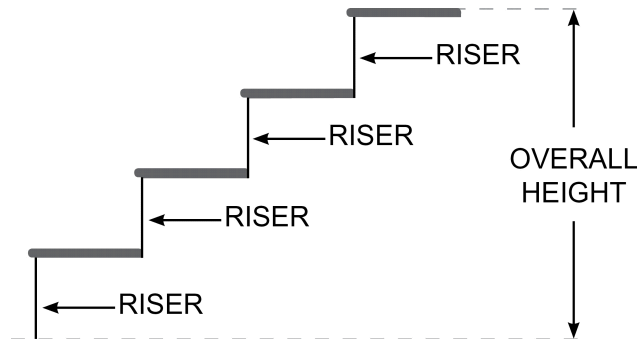

- (i) At least one handrail; and
- (ii) One stairrail system along each unprotected side or edge.

NOTE: When the top edge of a stairrail system also serves as a handrail, paragraph (c)(7) of this section applies.

(2) Winding and spiral stairways shall be equipped with a handrail offset sufficiently to prevent walking on those portions of the stairways where the tread width is less than 6 inches (15 cm).

(3) The height of stairrails shall be as follows:

(i) Stairrails installed after March 15, 1991, shall be not less than 36 inches (91.5 cm) from the upper surface of the stairrail system to the surface of the tread, in line with the face of the riser at the forward edge of the tread.

(ii) Stairrails installed before March 15, 1991, shall be not less than 30 inches (76 cm) nor more than 34 inches (88 cm) from the upper surface of the stairrail system to the surface of the tread, in line with the face of the riser at the forward edge of the tread.

(4) Midrails, screens, mesh, intermediate vertical members, or equivalent intermediate structural members, shall be provided between the top rail of the stairrail system and the stairway steps.

- (i) Midrails, when used, shall be located at a height midway between the top edge of the stairrail system and the stairway steps.
 - (ii) Screens or mesh, when used, shall extend from the top rail to the stairway step, and along the entire opening between top rail supports.
 - (iii) When intermediate vertical members, such as balusters, are used between posts, they shall be not more than 19 inches (48 cm) apart.
 - (iv) Other structural members, when used, shall be installed such that there are no openings in the stairrail system that are more than 19 inches (48 cm) wide.
- (5) Handrails and the top rails of stairrail systems shall be capable of withstanding, without failure, a force of at least 200 pounds (890 n) applied within 2 inches (5 cm) of the top edge, in any downward or outward direction, at any point along the top edge.
- (6) The height of handrails shall be not more than 37 inches (94 cm) nor less than 30 inches (76 cm) from the upper surface of the handrail to the surface of the tread, in line with the face of the riser at the forward edge of the tread.
- (7) When the top edge of a stairrail system also serves as a handrail, the height of the top edge shall be not more than 37 inches (94 cm) nor less than 36 inches (91.5 cm) from the upper surface of the stairrail system to the surface of the tread, in line with the face of the riser at the forward edge of the tread.
- (8) Stairrail systems and handrails shall be so surfaced as to prevent injury to employees from punctures or lacerations, and to prevent snagging of clothing.
- (9) Handrails shall provide an adequate handhold for employees grasping them to avoid falling.
- (10) The ends of stairrail systems and handrails shall be constructed so as not to constitute a projection hazard.
- (11) Handrails that will not be a permanent part of the structure being built shall have a minimum clearance of 3 inches (8 cm) between the handrail and walls, stairrail systems, and other objects.
- (12) Unprotected sides and edges of stairway landings shall be provided with guardrail systems. Guardrail system criteria are contained in Subdivision M of this part.

Stat. Auth.: ORS 654.025(2) and 656.726(3).

Hist: OR-OSHA Admin. Order 6-1991, f. 3/18/91, ef. 4/15/91.

§1926.1053 Ladders.

(a) General. The following requirements apply to all ladders as indicated, including job-made ladders.

(1) Ladders shall be capable of supporting the following loads without failure:

(i) Each self-supporting portable ladder: At least four times the maximum intended load, except that each extra-heavy-duty type 1A metal or plastic ladder shall sustain at least 3.3 times the maximum intended load. The ability of a ladder to sustain the loads indicated in this paragraph shall be determined by applying or transmitting the requisite load to the ladder in a downward vertical direction. Ladders built and tested in conformance with the applicable provisions of Appendix A of this subdivision will be deemed to meet this requirement.

(ii) Each portable ladder that is not self-supporting: At least four times the maximum intended load, except that each extra-heavy-duty type 1A metal or plastic ladders shall sustain at least 3.3 times the maximum intended load. The ability of a ladder to sustain the loads indicated in this paragraph shall be determined by applying or transmitting the requisite load to the ladder in a downward vertical direction when the ladder is placed at an angle of 75-1/2 degrees from the horizontal. Ladders built and tested in conformance with the applicable provisions of Appendix A will be deemed to meet this requirement.

(iii) Each fixed ladder: At least two loads of 250 pounds (114 kg) each, concentrated between any two consecutive attachments (the number and position of additional concentrated loads of 250 pounds (114 kg) each, determined from anticipated usage of the ladder, shall also be included), plus anticipated loads caused by ice buildup, winds, rigging, and impact loads resulting from the use of ladder safety devices. Each step or rung shall be capable of supporting a single concentrated load of at least 250 pounds (114 kg) applied in the middle of the step or rung. Ladders built in conformance with the applicable provisions of Appendix A will be deemed to meet this requirement.

(2) Ladder rungs, cleats, and steps shall be parallel, level, and uniformly spaced when the ladder is in position for use.

(3)

(i) Rungs, cleats, and steps of portable ladders (except as provided below) and fixed ladders (including individual rung/step ladders) shall be spaced not less than 10 inches (25 cm) apart, nor more than 14 inches (36 cm) apart, as measured between center lines of the rungs, cleats and steps.

(ii) Rungs, cleats, and steps of step stools shall be not less than 8 inches (20 cm) apart, nor more than 12 inches (31 cm) apart, as measured between center lines of the rungs, cleats, and steps.

- (iii) Rungs, cleats, and steps of the base section of extension trestle ladders shall be not less than 8 inches (20 cm) nor more than 18 inches (46 cm) apart, as measured between center lines of the rungs, cleats, and steps. The rung spacing on the extension section of the extension trestle ladder shall be not less than 6 inches (15 cm) nor more than 12 inches (31 cm), as measured between center lines of the rungs, cleats and steps.
- (4)
- (i) The minimum clear distance between the sides of individual-rung/step ladders and the minimum clear distance between the side rails of other fixed ladders shall be 16 inches (41 cm).
- (ii) The minimum clear distance between side rails for all portable ladders shall be 11-1/2 inches (29 cm).
- (5) The rungs of individual-rung/step ladders shall be shaped such that employees' feet cannot slide off the end of the rungs.
- (6)
- (i) The rungs and steps of fixed metal ladders manufactured after March 15, 1991, shall be corrugated, knurled, dimpled, coated with skid-resistant material, or otherwise treated to minimize slipping.
- (ii) The rungs and steps of portable metal ladders shall be corrugated, knurled, dimpled, coated with skid-resistant material, or otherwise treated to minimize slipping.
- (7) Ladders shall not be tied or fastened together to provide longer sections unless they are specifically designed for such use.
- (8) A metal spreader or locking device shall be provided on each stepladder to hold the front and back sections in an open position when the ladder is being used.
- (9) When splicing is required to obtain a given length of side rail, the resulting side rail must be at least equivalent in strength to a one-piece side rail made of the same material.
- (10) Except when portable ladders are used to gain access to fixed ladders (such as those on utility towers, billboards, and other structures where the bottom of the fixed ladder is elevated to limit access), when two or more separate ladders are used to reach an elevated work area, the ladders shall be offset with a platform or landing between the ladders. (The requirements to have guardrail systems with toeboards for falling object and overhead protection on platforms and landings are set forth in Subdivision M of this part.)

(11) Ladder components shall be surfaced so as to prevent injury to an employee from punctures or lacerations, and to prevent snagging of clothing.

(12) Wood ladders shall not be coated with any opaque covering, except for identification or warning labels which may be placed on one face only of a side rail.

(13) The minimum perpendicular clearance between fixed ladder rungs, cleats, and steps, and any obstruction behind the ladder shall be 7 inches (18 cm), except in the case of an elevator pit ladder, for which a minimum perpendicular clearance of 4-1/2 inches (11 cm) is required.

(14) The minimum perpendicular clearance between the center line of fixed ladder rungs, cleats, and steps, and any obstruction on the climbing side of the ladder shall be 30 inches (76 cm), except as provided in paragraph (a)(15) of this section.

(15) When unavoidable obstructions are encountered, the minimum perpendicular clearance between the centerline of fixed ladder rungs, cleats, and steps, and the obstruction on the climbing side of the ladder may be reduced to 24 inches (61 cm), provided that a deflection device is installed to guide employees around the obstruction.

(16) Through fixed ladders at their point of access/egress shall have a step-across distance of not less than 7 inches (18 cm) nor more than 12 inches (30 cm) as measured from the centerline of the steps or rungs to the nearest edge of the landing area. If the normal step-across distance exceeds 12 inches (30 cm), a landing platform shall be provided to reduce the distance to the specified limit.

(17) Fixed ladders without cages or wells shall have a clear width to the nearest permanent object of at least 15 inches (38 cm) on each side of the centerline of the ladder.

(18) Fixed ladders shall be provided with cages, wells, ladder safety devices, or self-retracting lifelines where the length of climb is less than 24 feet (7.3 m) but the top of the ladder is at a distance greater than 24 feet (7.3 m) above lower levels.

(19) Where the total length of a climb equals or exceeds 24 feet (7.3 m), fixed ladders shall be equipped with one of the following:

(i) Ladder safety devices; or

(ii) Self-retracting lifelines, and rest platforms at intervals not to exceed 150 feet (45.7 m); or

(iii) A cage or well, and multiple ladder sections, each ladder section not to exceed 50 feet (15.2 m) in length. Ladder sections shall be offset from adjacent sections, and landing platforms shall be provided at maximum intervals of 50 feet (15.2 m).

(20) Cages for fixed ladders shall conform to all of the following:

- (i) Horizontal bands shall be fastened to the side rails of rail ladders, or directly to the structure, building, or equipment for individual-rung ladders;
 - (ii) Vertical bars shall be on the inside of the horizontal bands and shall be fastened to them;
 - (iii) Cages shall extend not less than 27 inches (68 cm), or more than 30 inches (76 cm) from the centerline of the step or rung (excluding the flare at the bottom of the cage), and shall not be less than 27 inches (68 cm) in width;
 - (iv) The inside of the cage shall be clear of projections;
 - (v) Horizontal bands shall be spaced not more than 4 feet (1.2 m) on center vertically;
 - (vi) Vertical bars shall be spaced at intervals not more than 9-1/2 inches (24 cm) on center horizontally;
 - (vii) The bottom of the cage shall be at a level not less than 7 feet (2.1 m) nor more than 8 feet (2.4 m) above the point of access to the bottom of the ladder. The bottom of the cage shall be flared not less than 4 inches (10 cm) all around within the distance between the bottom horizontal band and the next higher band;
 - (viii) The top of the cage shall be a minimum of 42 inches (1.1 m) above the top of the platform, or the point of access at the top of the ladder, with provision for access to the platform or other point of access.
- (21)** Wells for fixed ladders shall conform to all of the following:
- (i) They shall completely encircle the ladder;
 - (ii) They shall be free of projections;
 - (iii) Their inside face on the climbing side of the ladder shall extend not less than 27 inches (68 cm) nor more than 30 inches (76 cm) from the centerline of the step or rung;
 - (iv) The inside clear width shall be at least 30 inches (76 cm);
 - (v) The bottom of the wall on the access side shall start at a level not less than 7 feet (2.1 m) nor more than 8 feet (2.4 m) above the point of access to the bottom of the ladder.
- (22)** Ladder safety devices, and related support systems, for fixed ladders shall conform to all of the following:
- (i) They shall be capable of withstanding without failure a drop test consisting of an 18-inch (41 cm) drop of a 500-pound (226 kg) weight;

(ii) They shall permit the employee using the device to ascend or descend without continually having to hold, push or pull any part of the device, leaving both hands free for climbing;

(iii) They shall be activated within 2 feet (.61 m) after a fall occurs, and limit the descending velocity of an employee to 7 feet/sec. (2.1 m/sec.) or less;

(iv) The connection between the carrier or lifeline and the point of attachment to the body belt or harness shall not exceed 9 inches (23 cm) in length.

(23) The mounting of ladder safety devices for fixed ladders shall conform to the following:

(i) Mountings for rigid carriers shall be attached at each of the carrier, with intermediate mountings, as necessary, spaced along the entire length of the carrier, to provide the strength necessary to stop employees' falls.

(ii) Mountings for flexible carriers shall be attached at each end of the carrier. When the system is exposed to wind, cable guides for flexible carriers shall be installed at a minimum spacing of 25 feet (7.6 m) and maximum spacing of 40 feet (12.2 m) along the entire length of the carrier, to prevent wind damage to the system.

(iii) The design and installation of mountings and cable guides shall not reduce the design strength of the ladder.

(24) The side rails of through or side-step fixed ladders shall extend 42 inches (1.1 m) above the top of the access level or landing platform served by the ladder. For a parapet ladder, the access level shall be the roof if the parapet is cut to permit passage through the parapet; if the parapet is continuous, the access level shall be the top of the parapet.

(25) For through-fixed-ladder extensions, the steps or rungs shall be omitted from the extension and the extension of the side rails shall be flared to provide not less than 24 inches (61 cm) nor more than 30 inches (76 cm) clearance between side rails. Where ladder safety devices are provided, the maximum clearance between side rails of the extensions shall not exceed 36 inches (91 cm).

(26) For side-step fixed ladders, the side rails and the steps or rungs shall be continuous in the extension.

(27) Individual-rung/step ladders, except those used where their access openings are covered with manhole covers or hatches, shall extend at least 42 inches (1.1 m) above an access level or landing platform either by the continuation of the rung spacings as horizontal grab bars or by providing vertical grab bars that shall have the same lateral spacing as the vertical legs of the rungs.

(b) Use. The following requirements apply to the use of all ladders, including job-made ladders, except as otherwise indicated:

- (1)** When portable ladders are used for access to an upper landing surface, the ladder side rails shall extend at least 3 feet (.9 m) above the upper landing surface to which the ladder is used to gain access; or, when such an extension is not possible because of the ladder's length, then the ladder shall be secured at its top to a rigid support that will not deflect, and a grasping device, such as a grabrail, shall be provided to assist employees in mounting and dismounting the ladder. In no case shall the extension be such that ladder deflection under a load would, by itself, cause the ladder to slip off its support.
- (2)** Ladders shall be maintained free of oil, grease, and other slipping hazards.
- (3)** Ladders shall not be loaded beyond the maximum intended load for which they were built, nor beyond their manufacturer's rated capacity.
- (4)** Ladders shall be used only for the purpose for which they were designed.
- (5)**

 - (i)** Non-self-supporting ladders shall be used at an angle such that the horizontal distance from the top support to the foot of the ladder is approximately one-quarter of the working length of the ladder (the distance along the ladder between the foot and the top support).
 - (ii)** Wood job-made ladders with spliced side rails shall be used at an angle such that the horizontal distance is one-eighth the working length of the ladder.
 - (iii)** Fixed ladders shall be used at a pitch no greater than 90 degrees from the horizontal, as measured to the back side of the ladder.
- (6)** Ladders shall be used only on stable and level surfaces unless secured to prevent accidental displacement.
- (7)** Ladders shall not be used on slippery surfaces unless secured or provided with slip-resistant feet to prevent accidental displacement. Slip-resistant feet shall not be used as a substitute for care in placing, lashing, or holding a ladder that is used upon slippery surfaces including, but not limited to, flat metal or concrete surfaces that are constructed so they cannot be prevented from becoming slippery.
- (8)** Ladders placed in any location where they can be displaced by workplace activities or traffic, such as in passageways, doorways, or driveways, shall be secured to prevent accidental displacement, or a barricade shall be used to keep the activities or traffic away from the ladder.
- (9)** The area around the top and bottom of ladders shall be kept clear.
- (10)** The top of a non-self-supporting ladder shall be placed with the two rails supported equally unless it is equipped with a single support attachment.

- (11) Ladders shall not be moved, shifted, or extended while occupied.
- (12) Ladders shall have nonconductive siderails if they are used where the employee or the ladder could contact exposed energized electrical equipment, except as provided in §1926.951(c)(1) of this part.
- (13) The top or top step of a stepladder shall not be used as a step.
- (14) Cross-bracing on the rear section of stepladders shall not be used for climbing unless the ladders are designed and provided with steps for climbing on both front and rear sections.
- (15) Ladders shall be inspected by a competent person for visible defects on a periodic basis and after any occurrence that could affect their safe use.
- (16) Portable ladders with structural defects, such as, but not limited to, broken or missing rungs, cleats, or steps, broken or split rails, corroded components, or other faulty or defective components, shall either be immediately marked in a manner that readily identifies them as defective, or be tagged with “Do Not Use” or similar language, and shall be withdrawn from service until repaired.
- (17) Fixed ladders with structural defects, such as, but not limited to, broken or missing rungs, cleats, or steps, broken or split rails, or corroded components, shall be withdrawn from service until repaired. The requirement to withdraw a defective ladder from service is satisfied if the ladder is either:
- (i) Immediately tagged with “Do Not Use” or similar language.
 - (ii) Marked in a manner that readily identifies it as defective;
 - (iii) Or blocked (such as with a plywood attachment that spans several rungs).
- (18) Ladder repairs shall restore the ladder to a condition meeting its original design criteria, before the ladder is returned to use.
- (19) Single-rail ladders shall not be used.
- (20) When ascending or descending a ladder, the user shall face the ladder.
- (21) Each employee shall use at least one hand to grasp the ladder when progressing up and/or down the ladder.
- (22) An employee shall not carry any object or load that could cause the employee to lose balance and fall.

Stat. Auth.: ORS 654.025(2) and 656.726(3).
Hist: OR-OSHA Admin. Order 6-1991, f. 3/18/91, ef. 4/15/91.

Additional Oregon Rule For Ladders

NOTE: OAR 437-003-0050, 0055, and 0060 were repealed by OR-OSHA Admin. Order 1-1994, filed 4/27/94, effective 4/27/94.

437-003-0065 *Extension Ladders.* *Extension ladders shall be equipped with necessary guide irons, locks, and hooks and shall be assembled so that the sliding (upper) section shall be on top of the base (lower) section.*

Stat. Auth.: ORS 654.025(2) and 656.726(3).

Hist: APD Admin. Order 8-1989, f. 7/7/89, ef. 7/7/89.

OR-OSHA Admin. Order 6-1991, f. 12/16/91, ef. 1/1/92.

§§1926.1054 – 1926.1059 (RESERVED)

X TRAINING REQUIREMENTS

§1926.1060 Training Requirements.

The following training provisions clarify the requirements of §1926.21(b)(2), regarding the hazards addressed in Subdivision X.

(a) The employer shall provide a training program for each employee using ladders and stairways, as necessary. The program shall enable each employee to recognize hazards related to ladders and stairways, and shall train each employee in the procedures to be followed to minimize these hazards.

(1) The employer shall ensure that each employee has been trained by a competent person in the following areas, as applicable:

(i) The nature of fall hazards in the work area;

(ii) The correct procedures for erecting, maintaining, and disassembling the fall protection systems to be used;

(iii) The proper construction, use, placement, and care in handling of all stairways and ladders;

(iv) The maximum intended load-carrying capacities of ladders used; and

(v) The standards contained in this subdivision.

(b) Retraining shall be provided for each employee as necessary so that the employee maintains the understanding and knowledge acquired through compliance with this section.

Stat. Auth.: ORS 654.025(2) and 656.726(3).

Hist: OR-OSHA Admin. Order 6-1991, f. 3/18/91, ef. 4/15/91.

Appendix A to Subdivision X – Ladders

This appendix serves as a non-mandatory guideline to assist employers in complying with the ladder loading and strength requirements of §1926.1053(a)(1). A ladder designed and built in accordance with the applicable national consensus standards, as set forth below, will be considered to meet the requirements of §1926.1053(a)(1):

- Manufactured portable wood ladders: American National Standards Institute (ANSI) A14.1-1982 – American National Standard for Ladders – Portable Wood – Safety Requirements.
- Manufactured portable metal ladders: ANSI A14.2-1982 – American National Standard for Ladders – Portable Metal – Safety Requirements.
- Manufactured fixed ladders: ANSI A14.3-1984 – American National Standard for Ladders – Fixed – Safety Requirements.
- Job-made ladders: ANSI A14.4-1979 – Safety Requirements for Job-Made Ladders.
- Plastic ladders: ANSI A14.5-1982 – American National Standard for Ladders – Portable Reinforced Plastic – Safety Requirements.

Stat. Auth.: ORS 654.025(2) and 656.726(3).

Hist: OR-OSHA Admin. Order 6-1991, f. 3/18/91, ef. 4/15/91.

(FR Doc. 90-26520 filed 11-13-90; 8:45 am)

BILLING CODE 4510-26-M

– END OF DOCUMENT –

